

ARO® Motion Control

Electronic / Pneumatic Logic Control Elements



Check Out These Other IR Industrial Productivity Solutions

- **Ingersoll-Rand Air Solutions:**
Air Compressors
- **Ingersoll-Rand Professional Tools:**
Hand Tools / Hoists
Zimmerman Material Handling



- **Fluid Handling**
ARO
McCartney Polyethylene (Waterjet)
- **Club Car**
Carry All Carts



Ingersoll-Rand



www.ingersoll-rand.com

Numeric Index

Number	Page	Number	Page	Number	Page	Number	Page	Number	Page
20191	39	59155	36	59671-X	37	59861	18	59922	22
24130	41	59156	35	59690-X	45	59866	39	59923	22
58027	42	59157	36	59718	37	59874	36	59924	22
58060	42	59158	35	59724-X	41	59875	36	59925	22
59003-842	17	59159	36	59756-XXX	45	59879	35	11860X-X	6
59010	34	59160	35	59757-XXX	45	59880	35	119435-X	9
59023	34	59161-X	38	59759-XX	45	59881	36	119436-X	7,9
59061	40	59162-X	38	59760-XX	45	59882	36	119437-X	7,9
59062	40	59165-4	36	59761-Xx	45	59890	39	119438-X	5,7,9,10,15
59063	40	59166-4	35	59762-XX	45	59891	39	119557	5,7,9
59073	41	59175-X	38	59763-X	45	59892	35	11958X-X	12
59084	41	59176-X	38	59764-4	45	59895	21	119775	10
59089	39	59181	34	59765-XX	45	59896	21	119779-X	5,7,9,10,15
59095-X	43	59185	34	59792	42	59897	21	119811-X	12
59097-6	42	59191	17	59796-X	41	59898	21	119812-X	12
59107	41	59192	17	59800	34	59899	21	119816-X	6
59109	39	59200-XX	40	59801	43	5990X	45	119817-X	10
59100-XXX	44	59201-XX	40	59802	43	59900	21	119818-X	10
59111	34	59361	42	59803	41	59903	45	119819-X	10
59112	34	59387	40	59804	41	59908	45	119820-X	10
59113	34	59422	41	59807	45	59912	34	119897-XX	12
59114	36	59474-XXX	45	59808	17	59913	18	AXXXXX-XXX-X	6
59115	37	59482	45	59809	17	59914	18	GMP1XX	8
59116	37	59595-XX	40	59811-X	41	59915-XX	39	GP1XXX-XXX-X	8
59117	37	59629	45	59812-X	41	59916-X	44	MKN	6
59120	36	5963X-100	45	59837	40	59917	18	MKP	6
59121	35	59632-1	45	59836	43	59919-1	22	SMH51X-XX-X	4
59124	34	59634	45	59842	45	59920	22	S5XXXX	4
59125	34	59636	45	59860	18	59921	22	TNXXX-XXXXX-XXX	15

Table of Contents

Series	Page
Easy Wire Systems	
Sierra	4-5
Alpha	6-7
Genesis	8-9
Interceptor	10-12
Technical Data	13
Transducer Cylinder	14-15
ARO Pneumatic Logic Controls	
Specifications	16
Two-Hand Anti-Tie-Down	17
Flex-6 Accessory Units	18
Flex-6 Controls	19-33
Logic Elements	34-40
Indicators	41
Enclosures	42
Counters	43
Rotary Selectors	44
Liquid Level Sensors	44
Fittings	45



Features

ELC Systems Communications allows you to interface the best fluid power products with your PLC, or PC. If you've been searching for a simple, direct and inexpensive path to electronic orchestration of your machine assembly process, then consider ELC.

- Do away with Hardwiring Headaches! Circuit boards replace traditional wiring. Simple manifold-to-manifold connections.
- Split Stack Capabilities. Separate valves into two or more banks, but still control them over one cable from the PLC, without starting a second node (16-solenoids maximum).
- No BIG Control Box at the end of each valve stack. A MAJOR cost & space savings.
- Three Levels of Communication: Parallel, Serial Interface and DeviceNet™.
- Surge suppression for every solenoid-standard.

DOBCO
EQUIPMENT LTD

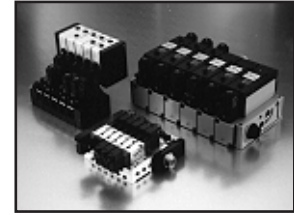

AroNet™ DeviceNet

- Fully DeviceNet Compatible.
- Split Stack Wiring Capability on Alpha & Genesis.
- Controls up to 16 Solenoids/Inputs per node.
- Start a second node in the middle of a valve stack. (Genesis only)
- Add/Remove Valves in Minutes.
- External Power Available.
- Available for Genesis, Alpha and Sierra Valves.
- Available with Interceptor Input Block

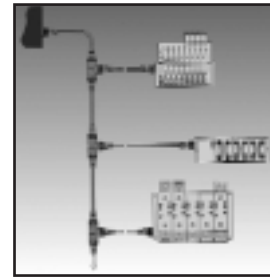

AroLink™ Serial Interface

- Controls up to 16 Solenoids/Inputs per Wire.
- Works with ANY make Discrete Output PLC.
- Quick, Single-to-Double Solenoid Conversion.
- Split Stack Wiring Capability.
- Compatible with Omron® Link Terminals, or direct connection to Omron PLC's (B7A language).
- Available for Genesis, Alpha and Sierra Valves.
- Available with Interceptor Input Block.

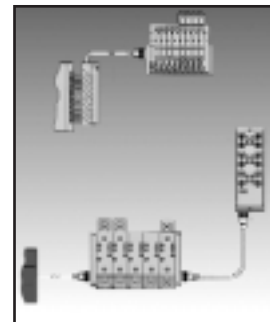

AroCom™ Parallel

- Controls up to 15 Solenoids.
- Add/Remove Valves in Minutes.
- Split Stack Wiring Capability.
- Very Low Power Draw with Aro Low-Watt Solenoid.
- Easy Single-to-Double Solenoid Conversion.
- Available for Genesis and Alpha Valves.
- Operates off TTL (3.4V) to 24V Signal.

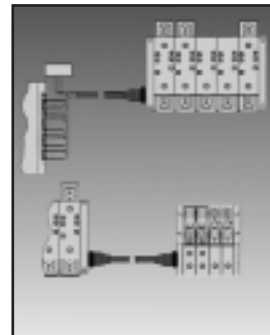

Features

DOBCO
EQUIPMENT LTD

AroLink and AroNet (DeviceNet) Systems carry signals to valve stacks over this small cable; eliminating the need for clumsy bundles of direct connection wires - dramatically reducing both space consumption and your valuable installation time. AroCom system is controlled over a cable.

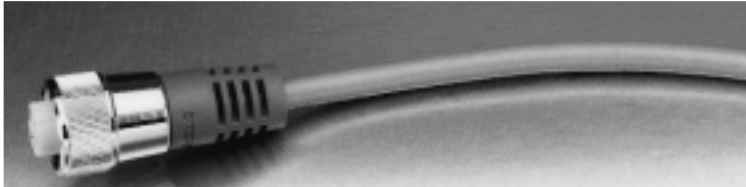

ELC Systems for Genesis Valves

- Available in AroNet, AroLink and AroCom configurations. For use with *Plug-In* Valves.
- ELC intelligence is located within the manifold raceway.
- The first manifold requires an AroNet or AroLink smart card. Other manifolds use AroCom driver cards, including split stack manifolds.

ELC Systems for Alpha Valves

- Available in AroNet, AroLink and AroCom configurations. For use with Stacking or Thin Valves.
- ELC Intelligence is located within the valve raceway.
- The first valve requires an AroNet or AroLink smart card. Other valves use AroCom driver cards, including split stack valves.

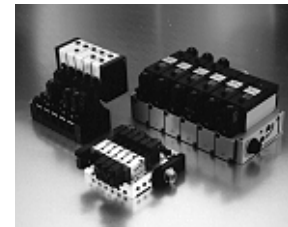

Alpha, Genesis and Sierra Valve ELC Systems

ELC Systems for Sierra Valves

- Available in AroNet and AroLink configurations. For use with any Sierra body style.
- ELC intelligence is located within the manifold assembly.

Interceptor™ Input Block

Interceptor™ Input Block

- Allows Multiple 24V DC Sensors to Communicate on One Cable.
- Features 12mm 4-Pin Connectors or Watertight Compression Fittings.
- Modular Design consists of one Command Module (AroLink or AroNet) and as many Sensor Modules as required; in packs of 4 Inputs, up to 16 Inputs total.
- Additional Modules can be quickly added/removed from the system.



Interceptor™ Input Block

Ordering



Base-Mounted Valves

S5 X X 9 X

Sierra Valve Size	
Code	Description
5	15 mm

Number of Coils	
Code	Description
S	Single Solenoid, Spring Return
D	Double Solenoid

Valve Style	
Code	Description
S	Standard Solenoid Operator

Coil Style/ Voltage	
Code	Description
B	Lead Wire, 24V DC
D	Plug-In Wire, 24V DC

Body Style	
Code	Description
9	Base Mounted

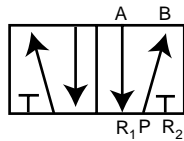

Sierra ELC Manifold (Valves sold separately)

ELC Manifold S M H 5 1 R - 06 - B

Code	Description
S	Sierra 15mm Valve Manifold with 1/8 NPT Cylinder Ports
M	Manifold
H	Manifold
5	Manifold
1	Manifold
R	Wiring Configuration: AroLink Manifold
V	Wiring Configuration: AroNet (DeviceNet) Manifold
06	Number of Stations: 6-Station
B	Output Connector (If Any): Serial Out



Sierra ELC

Sierra Wiring Kits

- 119822 -1 Plug-In Wire and Watertight Grommet Kit for Single Solenoid
- 2 Plug-In Wire and Watertight Grommet Kit for Double Solenoid
- 119751 -1 Watertight Grommet Only for Single Solenoid
- 2 Watertight Grommet Only for for Double Solenoid

Accessories

Transmitter Terminal (For AroLink System)

119557 Transmitter converts 24 PNP-Compatible, 16 inputs to AroLink signal

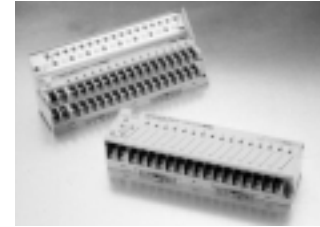

119557

Cables (For AroLink Sierra)

119438-1 5-Wire Serial Communication Cable with Plug on One End and 5 (ea.) stripped wires on other. 12-ft. Length
 119438-2 Same as -1, except 30-ft. Length.



119438-1

Patch Cables (Serial Out-to-Serial-In, Device-to-Device)

119779-1 Male/Female 5-pin Patch Cable for AroLink - 6 ft.
 -2 Male/Female 5-pin Patch Cable for AroLink - 12 ft.



119779-X

DOBCO
EQUIPMENT LTD

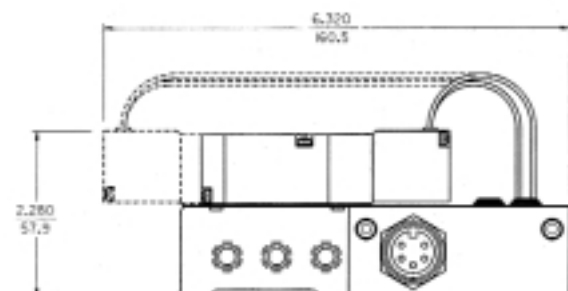
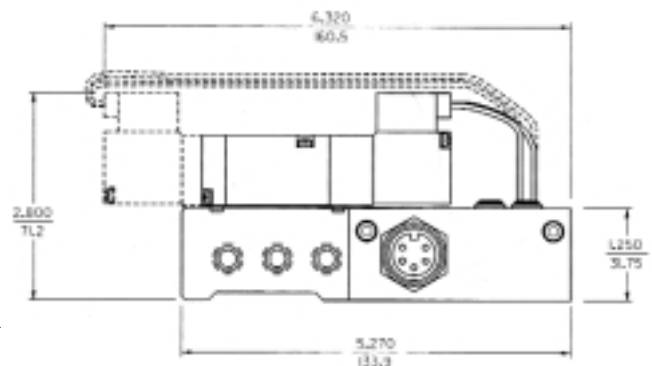
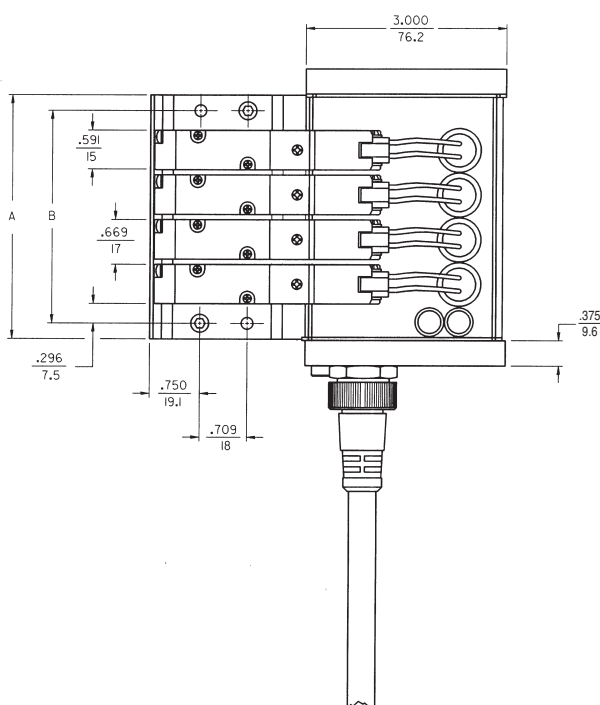

Ordering

ALPHA™

A X X X XX - XXX - X

Alpha Series

Valve, Spool Type

Code	Description
2	2-Position, Urethane
3	3-Position, Urethane
8	3-Position, Viton (3 & 8 are Spring Centered, all ports blocked in neutral. Available only with SD Actuators)
4	2-Position, Viton
7	3-Position, Urethane
9	3-Position, Viton (7 & 9 are Spring Centered, inlet ports blocked (cylinder ports open) in neutral. Available only with SD Actuators)

Valve Body Styles

Code	Description
2	4-Way, Stacking Valves
4	4-Way, Alpha Thin Valves

Current Type

Code	Description
R	AroLink Valve
V	AroNet (DeviceNet) Valve
W	AroCom Valve

Coil Voltage

Code	Description
024	24V DC

Actuator/Return

Code	Description
SS	Solenoid/Spring
SD	Solenoid/Solenoid

Port Size

Code	Description
1	1/8" NPTF
2	1/4" NPTF
9	None (Alpha Thin Valves)



4-Way, 2-Position

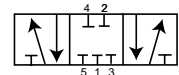

4-Way, 3-Position, all ports blocked in neutral

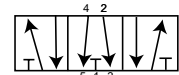

4-Way, 3-Position, cylinder ports open, inlet port blocked

Alpha "Thin" Manifold

11860X - X

Port Size

Code	Description
4	1/8" NPT
5	1/4" NPT

Consult factory for BSP Models.

Number of Stations

Code	Description
2	2 Station
4	4 Station
6	6 Station
8	8 Station
10	10 Station

Alpha ELC End Plates

For AroCom System

119816-1	Parallel In (Left) Parallel Out (Right)
-2	Parallel In (Left) Serial/External Power (Right)
-3	Parallel In (Left) Blank (Right)

For AroLink and AroNet

119816-4	Serial In (Left) Parallel Out (Right)
-5	Serial In (Left) Serial/External Power (Right)
-6	Serial In (Left) Blank (Right)

Valve Stacking End Plate

MKN	One MKN Kit is required to stack 1-to-6 Valves without Isolator Plates. Each contains 2 End Plates, 2 Cap Screws and 1 Gasket.
MKP	One MKN Kit is required to stack 7-to-12 Valves without Isolator Plates, or 1-to-12 Valves with an Isolator Plate. Each contains 2 End Plates, 2 Cap Screws and 1 Gasket.

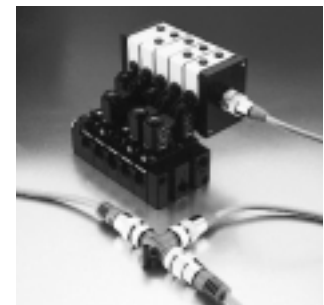

Alpha ELC

Ordering

Genesis



Genesis ELC

Plug-In Valves

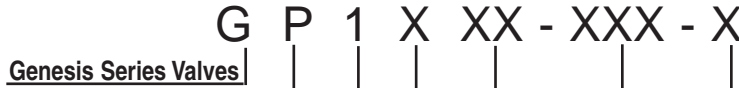

4-way subbase Plug-In (internally wired)

ISO Size 1

Valve, Spool Type

Code	Description
2	2-Position, Urethane
3	3-Position, Urethane
8	3-Position, Viton (3 & 8 are Spring Centered, all ports blocked in neutral. Available only with SD Actuators)
4	2-Position, Viton
7	3-Position, Urethane
9	3-Position, Viton (7 & 9 are Spring Centered, inlet ports blocked (cylinder ports open) in neutral. Available only with SD Actuators)

3-position models available only in SD, AD, ND, and MD actuators.

Coil Options

Code	Description
D	DC Std. Coil
J	DC St. coil/Cover Plate Light
L	DC Low Watt
P	DC Low Watt/Cover Plate Light

Coil Voltage

Code	Description
024	24V DC

Actuator / Return

Code	Description
SD	Double Solenoid
SF	Feathered Override, Single Solenoid
SS	Solenoid/Spring
ND	Double Solenoid-NEMA 4
NS	Solenoid/Spring-NEMA 4
AD	External Solenoid Pilot, Double Solenoid
AS	External Solenoid Pilot, Solenoid/Spring
MD	External Solenoid Pilot, Double Solenoid-NEMA 4
MS	External Solenoid Pilot, Solenoid/Spring-NEMA 4

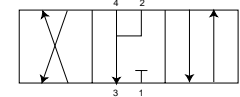
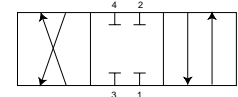
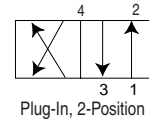

Plug-In Valve Manifold

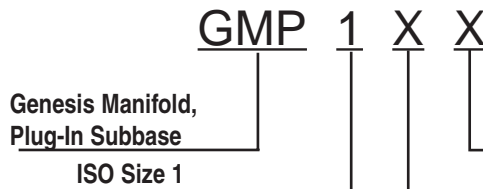

Port Size

Code	Description
2	1/4" NPT
3	3/8" NPT

Bottom ports are always 1/4".

Wiring Options

Code	Description
5	EasyWire AroNet (DeviceNet) System
6	EasyWire AroLink System
7	EasyWire AroCom System

See page 9 for End Plate ordering information.

SoftWire

Manifold

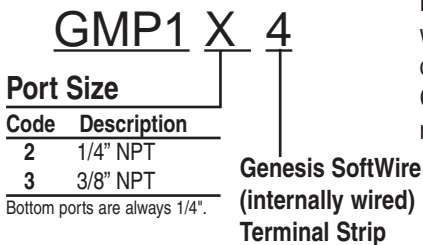

Low cost, Genesis SoftWire uses internal wiring in the manifold, but uses ELC cabling externally (119437-X). Order Genesis valves from above. Order manifold and end plates at left.

End Plates

- 119435-9 Parallel In (Left), Nothing Out with Air (Port) connections (Right).
- 119435-10 Parallel In (Left), Nothing Out (Right).

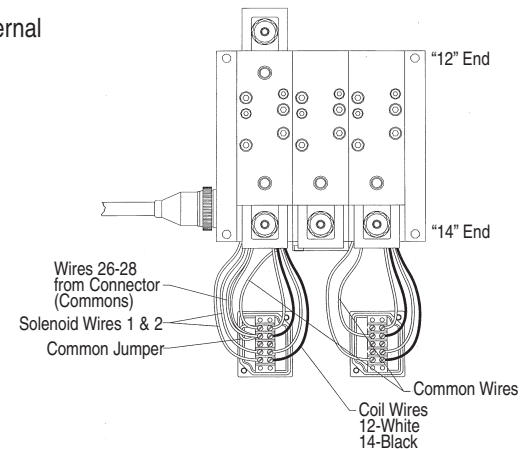

Accessories



End Plates (For AroCom System)

- 119435 -1 Parallel In (Left), Parallel Out (Right)
- 2 Parallel In (Left), External Power/Serial Out (Right)
- 3 Parallel In (Left), Nothing Out with Air (Port) connections (Right)
- 4 Parallel In (Left), Nothing Out (Right)

End Plates (For AroLink and AroNet)

- 119435 -5 Serial In (Left), Parallel Out (Right)
- 6 Serial In (Left), External Power/Serial Out (Right)
- 7 Serial In (Left), Nothing Out with Air (Port) Connections (Right)
- 8 Serial In (Left), Nothing Out (Right)



119436-1

Valve Cables (For AroCom Systems and Genesis)

- 119436-1 28-Wire Cable, Plugs on Both Ends, 6-ft.
- 2 28-Wire Cable, Plugs on Both Ends, 12-ft.
- 3 28-Wire Cable, Plugs on Both Ends, 24-ft.
- 119437-1 28-Wire Cable, Plugs on One End, 6-ft.
- 2 28-Wire Cable, Plugs on One End, 12-ft.
- 3 28-Wire Cable, Plugs on One End, 24-ft.

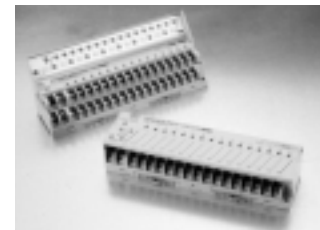

119557

Transmitter Terminal (For AroLink System)

- 119557 Transmitter converts 24 PNP-Compatible, 16 inputs to AroLink signal



119438-1

Cables (For AroLink Genesis and Interceptor)

- 119438-1 5-Wire Serial Communication Cable with Plug on One End and 5 (ea.) stripped wires on other. 12-ft. Length
- 119438-2 Same as -1, except 30-ft. Length.



119779-X

Patch Cables (Serial Out-to-Serial-In, Device-to-Device)

- 119779-1 Male/Female 5-pin Patch Cable for AroLink - 6 ft.
- 2 Male/Female 5-pin Patch Cable for AroLink - 12 ft.

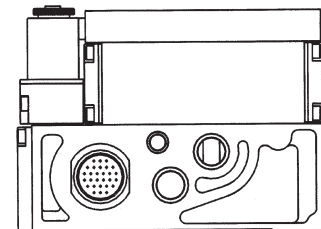
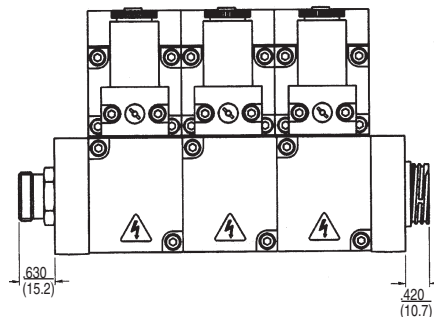
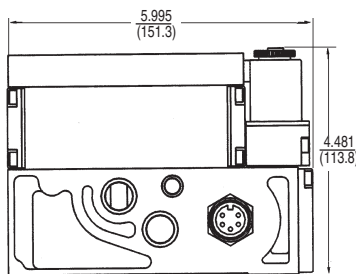

Features

- Allows Multiple Sensors to Communicate on One Cable.
- Available with 12mm 4-pin Connectors or Pass-Thru Water-Tight Compression Fittings.
- Field Convertible Models can be Sourcing or Sinking for Hall (3-Wire) or Reed (2 - Wire) Sensors.
- Totally Modular Design includes One Command Module (AroLink or AroNet) and as many Sensor Modules as Required - in Modules of 4 Inputs (Max. 4 Modules), up to 16 Inputs Total.
- Additional Sensor Modules can be Added/Removed Quickly.

Interceptor™



Interceptor

Accessories

Interceptor Modules

- 119818 -1 Command Module for AroNet (DeviceNet)
- 2 Command Module for AroLink
- 119819 -1 12mm Plug-In Sensor Module-Sourcing
- 2 12mm Plug-In Sensor Module-Sinking
- 3 12mm Plug-In Sensor Module-Reed
- 119820 -1 Compression Fitting Sensor Module-Sourcing/Reed
- 2 Compression Fitting Sensor Module-Sinking/Reed
- 119817 -1 Endplate Kit for Interceptor
- 2 Endplate Kit for Interceptor with Serial-In / Serial Out Connector



119818-X



119819-X



119820-X

Ordering

Interceptor Block Ordering Instructions

Interceptor blocks can be ordered and factory assembled in hundreds of possible configurations. Simply follow this module menu from left to right. If preferred, you can order individual modules from the table above-using the listed 8-digit model numbers.

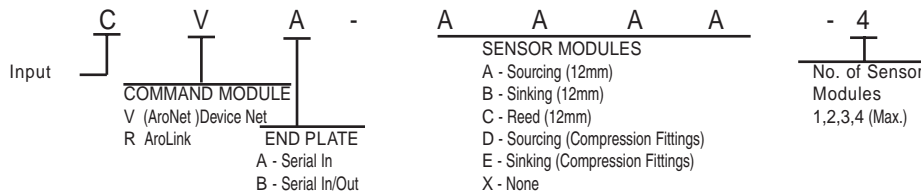

E X A M P L E S	C V A - B X X X - 1	AroNet Interceptor with single, 12mm plug-type module only.
	C V B - C C C C - 4	AroNet Interceptor with serial output connector and four, reed 12 mm plug-type modules.
	C R A - B A X X - 2	AroLink Interceptor with one sinking, and one sourcing, 12mm plug-type modules.

Note: Blocks containing compression fitting - style modules will be shipped unassembled.



119817-X

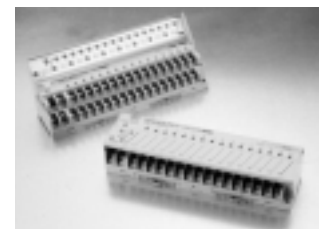

119775

Cables (For AroLink Genesis, Alpha, Sierra and Interceptor)

- 119438-1 5-Wire Serial Communication Cable with Plug on One End and 5 (ea.) stripped wires on other. 12-ft. Length
- 119438-2 Same as -1, except 30-ft. Length.



119438-1

Patch Cables (Serial Out-to-Serial-In, Device-to-Device)

- 119779-1 Male/Female 5-pin Patch Cable for AroLink - 6 ft.
- 2 Male/Female 5-pin Patch Cable for AroLink - 12 ft.



119779-X

Interceptor Receiver (For AroLink System)

- 119775 Receiver converts signal from Interceptor to 24V PNP-compatible outputs (16)

Dimensional Data

Interceptor™

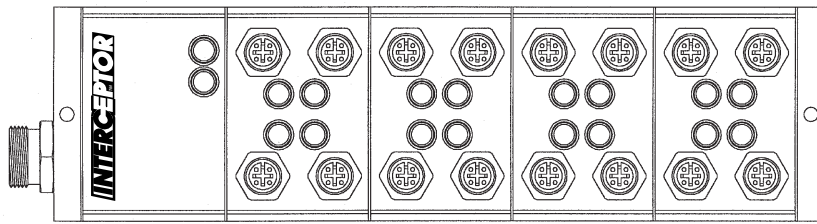

Interceptor Block

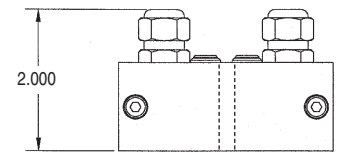
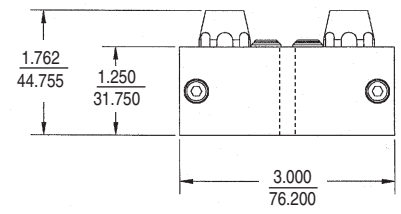
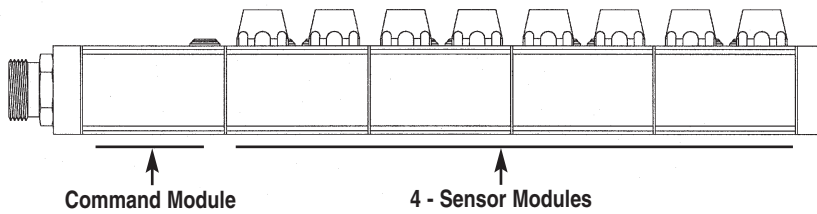
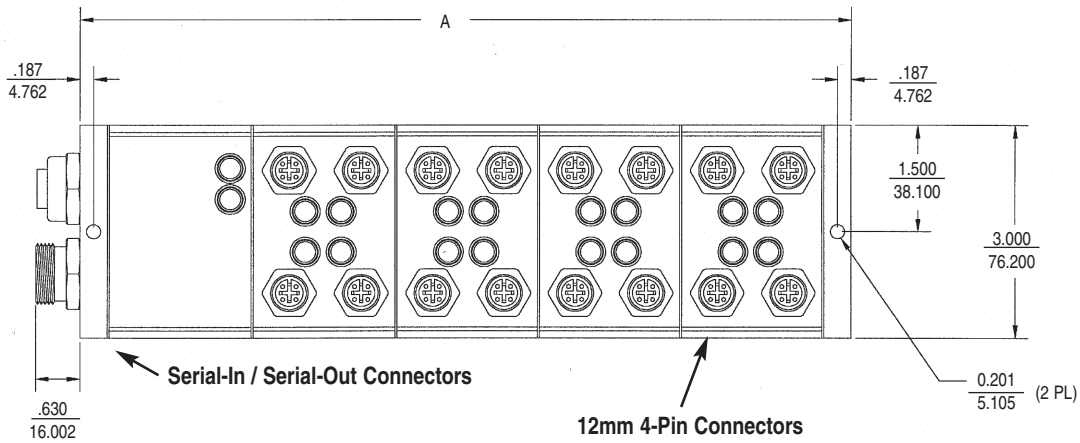

Compression Fittings

No. of Input Modules	"A"
1	4.740 (120.4)
2	6.724 (170.8)
3	8.707 (221.2)
4	10.691 (271.6)

Accessories

Interceptor™

Cylinder Position Switches

11958X-X See "Switch Specifications" below.



11958X-X

Switch Cables (Sensor-to-Device)

- 119811-1 8mm Connector Cable for Plug-On Switches (bare leads) - 6 ft.
- 2 8mm Connector Cable for Plug-On Switches (bare leads) - 12 ft.
- 119812-1 8mm Connector Cable for Plug-On Switches (12mm Interceptor Connection on opposite end) - 6 ft.
- 2 8mm Connector Cable for Plug-On Switches (12mm Interceptor Connection on opposite end) - 12 ft.



119811-X



119812-X

Switch Specifications

Model Number	119581-1	119581-2	119581-3	119582-1	119582-2	119582-3	119583-1	119583-2	119583-3
Lead Length/Type	1m bare	3m bare	Plug	1m bare	3m bare	Plug	1m bare	3m bare	Plug
Lead Color	Black			Grey			Black		
Switch Type	REED			PNP(SOURCING)			NPN (SINKING)		
Input Voltage	100 VDC, 125 VAC Max.			10 - 30 VDC			5 - 30 VDC		
Operating Current	300mA (150mA Inductive)			7 - 100mA @ 12V			5 - 100mA @ 5V		
				14 - 200mA @ 24V			10 - 200mA @ 12V		
							20 - 200mA @ 24V		
Detecting Distance	2.5 mm			1.5 mm			1.5 mm		
Detecting Width				3.0 mm			3.0 mm		
Response Time	1 mSec. Min.								
LED Function	18mA Min.			1mA Min.			1mA Min.		

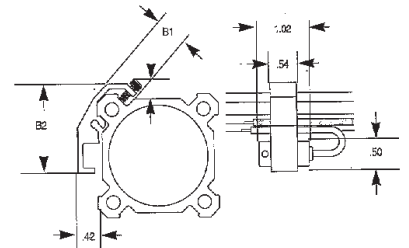

Provenair Switch Brackets

Bore	Model Number
1-1/2"	119584
2", 2-1/2"	119585
3-1/4" & 4"	119586

CYLINDER BORE (Inches)			
	1 1/2"	2 & 2 1/2"	3 1/4" & 4"
B1	.51	.60	.80
B2	1.50	1.77	2.45
B3	.26	.26	.33



Economair Switch Brackets

Bore	Model Number	Bore	Model Number
1-1/8"	119897-18	2-1/2"	119897-25
1-1/2"	119897-15	3"	119897-30
2"	119897-20	4"	119897-40

NOTE: Order bracket and switch separately.

Hall Effect Switches

It is important to note that Hall Effect switches must always have current through them to work. In a magnetic field, the semiconductor generates a voltage across the sense leads. Removing the magnetic field returns the switch to its normally open state. Hall effect switches have 'three wire' leads. Black leads are sinking (NPN). Grey leads are sourcing (PNP). Load is controller. There are two types of Hall Effect switches. Each is connected differently. Check your PLC for the input method used. Sinking (NPN) will sink current to ground. Sourcing (PNP) will provide current from the +VDC.

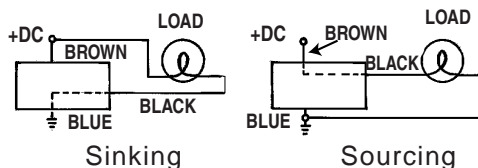

NOTE: Operating temperature is 14 - 140° F and the environmental rating is IEC IP 67 in all three switch types. Std. Red LED requires min 18 mA.

Reed Switches

Switch is normally open, load can be attached to BROWN or BLUE lead. The BROWN lead is the higher potential side of the switch. In a magnetic field, the two reeds are brought into contact to "make" the circuit. Reed switches have black, 'two wire' leads.

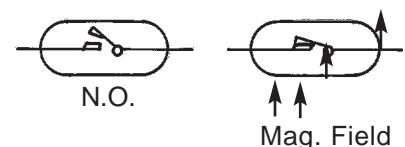

Technical Data

ELC General

	Low Watt Coil	Standard Coil
Power (VDC)	24	24
Current per Coil (mA)	75	240
Max. Solenoids ON at any time (per system of 16 coils)	16	12
Max. Temperature (deg. F)	240° (115°C)	240° (115°C)
Max. Pressure (psig)	115 (7.9 bar)	150 (10.3bar)

ELC System

	AroCom	AroLink	AroNet (DeviceNet)
Power (VDC)	24	24	24
Signal Voltage/Current	3.4V @ 3.4mA 24V @ 33mA	20V to 24V @ 6mA	
Max. Distance: Power at PLC	60 ft (18m)	50 ft (15m)	Refer to
External Power	100 ft (30m)	330 ft (100m)	DeviceNet
Dual Power	130 ft (40m)	1640 ft (500m)	Specifications
Max. Scan Time (mS)		19 (high speed 3mS available)	
PLC to be used	any discrete output DC (3.4V to 24V)	sourcing discrete output PLC (24V)	

AroNet Configuration

DIP Switch Configurations:	SW1	SW2	Baud Rate
	OPEN	OPEN	125k
	CLOSED	OPEN	250k
	OPEN	CLOSED	500k
Reset MAC ID to 63 @ Power On	CLOSED	CLOSED	Default Setting

LED Designations:	LED 1 (Module Status)	LED 2 (Network Status)
Solid Green	AroNet Receiving Power	AroNet Allocated
Flashing Green	AroNet Running through startup procedures	AroNet senses network, but is unable to communicate. Possible Node Allocation Collision.
Red (any form)	Not Applicable	Fault Mode. AroNet is unable to sense network. Possible failure to allocate a node on network.
Communication Type:	Pollied Device (Group 2 only slave)	
Bit Mapping Reservations:	16 Bit output word, additional enable bit dependent upon DeviceNet scanner/PLC interfacing..	

Features

Series TN

- Fully Repairable
- NFPA Interchangeable
- Infinite Resolution
- Factory Lubricated
- Factory Installed mounts or,
- Customer Installed mount kits



The Linear Resistive Transducer probe is completely inside the cylinder piston rod. There are no external parts (except the connector), therefore, the Provenair LRT is NFPA interchangeable. A floating contact, attached to the piston moves along the resistive and collector strips on the probe as the cylinder reciprocates. The linear resistance directly proportions the output voltage, indicating the position of the contact. Using a controller with an Analog card, cylinder position can be infinitely determined. Cylinder position can be controlled using a proportional valve. Accuracy is affected by 3 factors:

Resolution is the smallest detectable position change measurable. The Provenair LRT is infinite, thus the Resolution is limited by the electronics used (a 12-bit, 4096-part controller would divide the stroke into 4096 parts. Using 10 VDC input voltage, the smallest detectable increment on a 10" stroke will be $10 \div 4096 = 2.4$ millivolt = 0.0024").

Linearity is the reference to the maximum deviation of the output voltage to a straight line. The Provenair linearity is $\pm 0.5\%$ of stroke.

Repeatability is the LRT ability to output the same voltage at each unique position every time. The Provenair LRT repeatability is ± 0.0001 ".

Performance Specifications

Stroke:	600mm Max.
Rod Diameter:	5/8" or 1"
Resolution:	Infinite
Nonlinearity	1.0% (or less) of full stroke
Signal:	0-30VDC
Maximum Speed:	50" / sec. pneumatic 20" / sec. hydraulic
Probe Life:	7,500 miles
Nominal Resistance:	1 Kohm / stroke inch
Temperature:	-25°C to 100°C
Magnetic Interference:	None
Interface:	NEMA 4, Euro 12mm, 5 pin

Dimensional Data

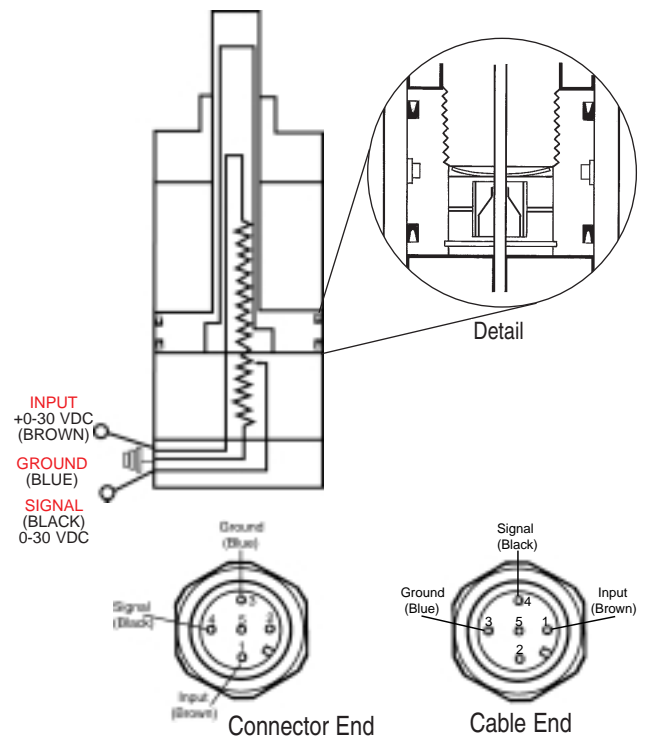

NEMA 4 12mm Male Eurostyle Connector

Pin 1	+ Input (Brown)
Pin 2	Not Used
Pin 3	Ground (Blue)
Pin 4	Signal (Black)
Pin 5	AGND (Not Used on connector end)

Ordering

Series TN (1-1/2" thru 4" Bore)

Include dashes (-). Dashes are significant.



ACTUATORS

Transducer Cylinders Begin With T

SERIES (NFPA)

All Provenair Cylinders are Series N

TYPE

A Double Acting,

BORE SIZE

Q	1- 1/2"	W	3-1/4"
S	2"	4	4"
T	2- 1/2"		

ROD DIAMETER

K	5/8"	Available:	1 1/2", 2", 2 1/2" bores.
M	1"	Available:	3 1/4", 4" bore.

ROD STYLE Stainless Steel Only

4	S.S., Standard Male (KK1) (Studded)	6	S.S., Full Male (CC) (Studded)
5	S.S., Intermediate Male (KK2) (Studded)	K	S.S., Female (KK1)

SEALS

S Slippery

CUSHIONS

- X No Cushions
- H Cushion Head End (Rod End)

PORT LOCATION (MS4 mounts: Port locations other than "A", call factory.)

A	H1, C1, P2 (Std.)	1	H1, C1, P4
B	H1, C2, P3	2	H1, C2, P1
C	H1, C3, P4	3	H1, C3, P2
D	H1, C4, P1	4	H1, C4, P3

Pin Connections
Always 90° From
Port.

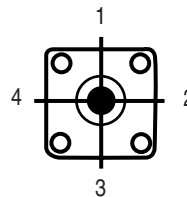

Determine
port
location
looking at
rod end of
cylinder.

MOUNT (MS4 mounts: Port locations other than A or 1 call factory.)

A	MS1	D	MP2	H	MF2	Q	MX1	U	MX3	1	FMB	3	FMH
C	MP1	F	MF1	K	MP4	T	MX2	X	No Mount	2	FMC		

STROKE

Inches		
Tens	Ones	
0-2	0-9	
Fractions		
0	=	0 in
1	=	1/8 in
2	=	1/4 in
3	=	3/8 in
4	=	1/2 in
5	=	5/8 in
6	=	3/4 in
7	=	7/8 in

NOTE:

Maximum stroke 24", for longer strokes contact factory.

NOTE:

Cap end port and connector (PIN) location must be determined looking at rod end of cylinder. Pin location will be 90° from cap port, available in either left or right quadrant. See below.

Typical Applications

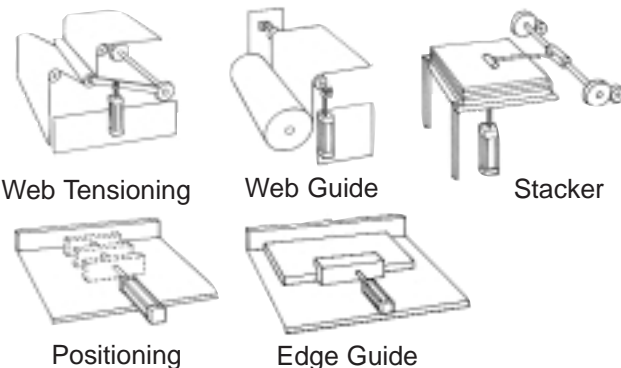

Standard Port and PIN Location

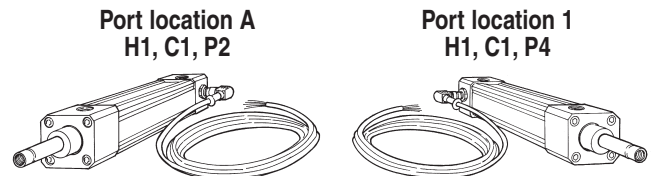

MS4 Mount Standard

NOTE: To obtain the MS4 mount with any other port locations, contact factory.

119438-1	Cables and Patch Cables See catalog page 10.
119438-2	
119779-1	
119779-2	

Features

Aro Pneumatic Logic Control Overview

Elements: Elements are miniature diaphragm operated poppet valves designed to perform specific functions. This includes "Or," "And," "Not," plus various "Memory" and "Delay" functions. Elements are designed so response times, shift ratios, flow and exhaust capacities are closely matched and all are compatible in a total system. This compatibility simplifies circuit design.

Circuit Board Construction: Aro's patented circuit board construction uses a gasket and two metal plates to create a custom air manifold. Interconnections between the elements are cut into the gasket (module) and sealed between the metal plates. The result is a completely interconnected circuit without tubing or fittings. Two gasket modules are used for more complex circuits. Circuit Boards produce a smaller circuit package at lower cost; increased tamper resistance; and provide a clean, neat assembly.

Function Base Assembly Method: A Function Base can be used when circuits require four or less elements. This consists of a gasket module, a thin metal plate and a porting strip. Interconnections between the elements are cut into the module. The porting strip has 1/8" NPTF ports, eliminating the need for porting blocks. This method can be mounted on any flat surface; it provides a neat, durable assembly; and it increases tamper resistance.

Back Tubulation Construction: This method uses a thin metal plate (base plate) and porting blocks for each element. Each block has built in fittings for 5/32" (4mm) tubing. Element interconnections are made by connecting tubes to these fittings. Back tubulation is often used for "bread boarding" new circuits, air circuit training and if circuits are frequently changed.

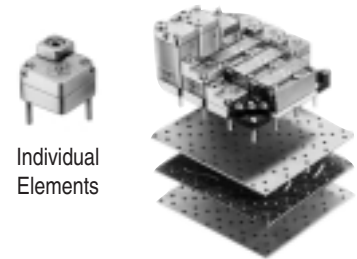

Individual Elements

Circuit Board Construction

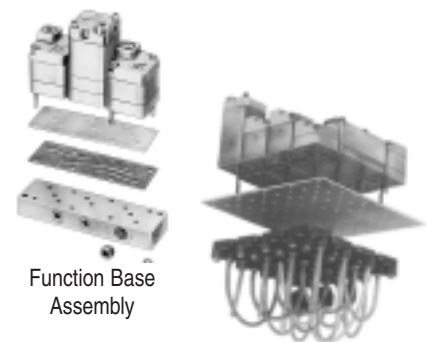

Function Base Assembly

Back Tubulation

Performance Specifications

Air Supply Preparation

Recommended Filtration: Filter air with a 40 micron filter or better. Additional screens in the base of timing function elements and amplifiers prevent large particles from entering the element.

Recommended Lubrication: None required for individual elements, or for circuits including timing functions or amplifiers.

Moisture: All metal parts are chromate plated to resist corrosion from moisture and many chemicals. A dry air supply is recommended for maximum repeatability of timing and sensing functions.

Operating Air:

Operating Pressure: 30-150 PSI (2-10 bar). Two-hand anti-tie-down devices require 50-125 PSI (3.5-9 bar).

Shift Pressures:

Snap-Acting Elements (And, Not, Inhibitor, S/R -- Mem, Delay and Pulse) shift when the pilot pressure exceeds 70% of the supply. They return when pilot pressure is less than 40% (Inhibitor 5%) of the supply.

Non-Snap-Acting Elements (Or -- Flip-Flop) have a shift pressure of 50% of supply pressure.

Flow & Cv Factors:

Dependent on specific elements and flow paths.
Flow = 9.3-16.2 SCFM, Cv = .14-.28

Identification:

Symbols: Each element has a symbol based on the National Standard for diagramming moving part logic control (attached method).

Port Identification: Letters cast into the cover and base of each element correspond to input and output designations.

Mounting: Elements have 5/8" (15.9mm) bolt extensions. All mounting hardware and seals are provided with each element.

Test Ports: Many elements have 1/8" NPT ports connected to the "C" (output) port. These can be used as optional output ports, or as test ports.

Anticipated Life:

Element Life: APLC elements have proven extremely durable, operating many millions of cycles, or several years, without failure. If needed, repair kits or parts are available for most elements.

Features

- Ideal for machines where position of operator's hands must be monitored.
- Actuate and hold both air valve buttons concurrently to maintain an output air signal. If either push button is released, the output air signal is exhausted, indicating the operator's hands are no longer in position.
- Operating Pressures: 50-125 PSI (3.5-8.6 bar). Designed to comply with OSHA regulations.
- See page 32 for additional information on hooking up 59191 signal elements.

Warning: These provide only the anti-tie down logic function and are not stroke limiting devices. On machines with full revolution clutches and/or where repeat cycles can occur, approved safety and/or single stroke devices must be used in conjunction with the anti-tie down units.

Elements

59191 Base Mounted

- Element has three 1/8" NPTF ports on top. 2 inputs, 1 output.
- Element is base mounted.

59192 Circuit Board Mounted

- Occupies six (6) element spaces, 2 x 3 on circuit board. Not designed for back tubulation construction.
- Element has two 1/8" NPTF input ports on top, one O-Ring sealed output port to circuit board.

Ordering Information: Order push button valves separately.

Packages

59808

- Includes two enclosures with green push button valves separated by a length of flexible conduit. External supply and output to machine is made by 5/32" (4mm) instant tube fittings.
- Comes assembled with all internal connections ready to install on machine.
- Palm Buttons are 30" center to center.

59809

- Green push buttons located on opposite ends of a single enclosure. External supply and output to machine is made by 5/32" (4mm) instant tube fittings.
- Comes assembled with all internal connections ready to install on machine.

59003-842

- Unassembled package.
- Includes 59191 anti-tie-down block, two 461-3 palm buttons with 20975 guards, 10 feet of 5/32" tubing and fittings for 59191.
- Customer can custom fit components to machine.



59191

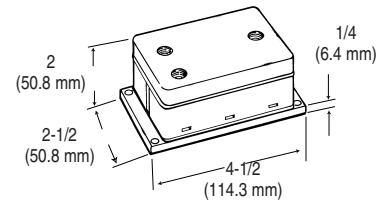

59192

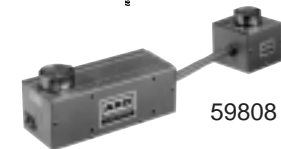
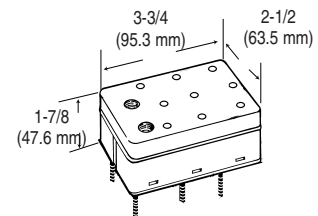

59808

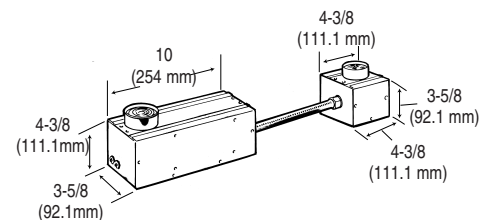

59809

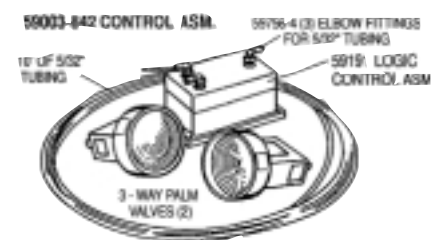
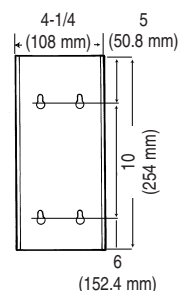
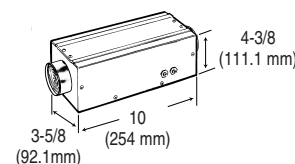

Accessories

59860 Signal Standardizer

- Converts an input signal of any duration into a timed output signal.
- Built in 4-way function in which two output signals are provided; one normally on, the other normally off.
- Can be used for 3-way and 4-way valves of all types including single and double pilot-operated models.
- Timing Range is 0.1 to 3 seconds. Longer with use of an accumulator. Each additional cu. in. of space added will give an extra 8 seconds of timing.
- Use filtered, dry, non-lubricated air. 40-125 psi (2-10.4 bar)
- See page 32 for additional information.



59860



59861



59917

59861 Oscillator Circuit

- Use in applications involving cycling and oscillating valves and cylinders for manufacturing and testing; as well as, pumping, sorting & painting.
- Has two dial timers so both phases can be adjusted independently.
- Can be used for all types of 3-way and 4-way valves.
- Recommended Timing Range of .1 to 3 seconds. Longer when using an accumulator. Each additional cu. in. of space added will give an extra 8 seconds of timing.
- See page 32 for additional information.

NOTE: For set-up or trouble-shooting, time delay functions can be adjusted far beyond their recommended range; however, if their normal operating time is longer than 3 seconds, additional volume should be connected to the port marked “Acu” (to the right of the adjustment dial). Each cubic inch additional volume connected to this port will increase the maximum range of the time delay by 8 seconds. A pressure gauge tee'd into the accumulator port can be very valuable as a visual aid when adjusting timers with extended ranges.

59917 Binary Flip-Flop

- With supply on, output one or output two will be on and the other off.
- Pressurizing the trigger port switches the outputs between on and off.

NOTE: All Flex-6 units have 10/32” ports.

Dimensions for Base Mounted Units Ports are 10/32 Threads

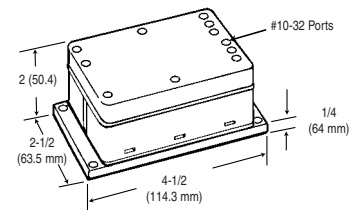
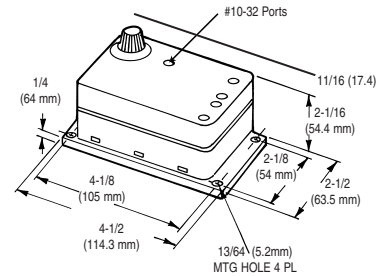

In Line Logic Elements

59914 “OR” Element

- Connects two inputs to one output. The output will be on when either, or both, inputs are on.



59914

59913 “AND” Element

- Connects two inputs to one output. The output will be on when both inputs are on.



59913

Operating Pressure: 30-150 PSIG (2-10 bar)

Operating Temperature: 32°-160°F (0°-71°C)

Ports: #10-32 threads

Shuttle/Poppet: Buna N

Body Material: Acetal Resin

Inserts: Aluminum

Flow: “OR” = 4 SCFM

Cv: “OR” = .11

“AND” = 3.2 SCFM

“AND” = .09

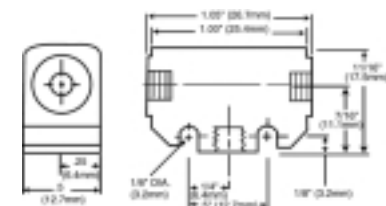

Features

Flex 6

Designed to Control Sequential Type Machines

- Simplifies design & installation of control circuits.
- Circuit changes or additions can be accomplished in seconds.
- Very economical for simple air operated machines and fixtures.
- Ideal for harsh and explosive environments.
- All ports are 10/32 threads.

Set/Reset Memory: The first step in each Flex-6 circuit is controlled by a set/reset memory. A momentary start signal pressurizes the set port, causes the memory to go on and starts the sequence. The memory remains on until the reset port is pressurized (end of cycle or emergency stop). Loss of supply pressure also resets the memory (output off).

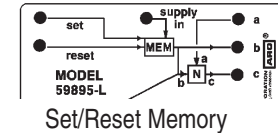

Automatic Reset Memory: Other Flex-6 memory functions automatically reset. A momentary signal at the set port causes the memory output to go on, provided the previous stage is on. The output will remain on until the entire circuit is reset. This memory has the ability to ignore signals arriving at the wrong time and will reset regardless of the set input condition. You don't need to analyze if the set signal is momentary or maintained, nor are you required to connect limit valves in series with a previous output.

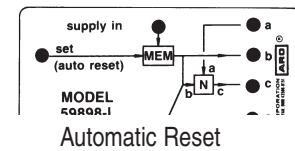

Timer Adjustment: Each time delay has a numbered dial (the numbers act as reference only). Screwdriver adjustment and fixed delay models are available on special order.

Adjustment Range: The recommended adjustment range is .1 to 3 seconds. If normal operating time is longer than 3 seconds, additional volume should be connected to the port marked "ACU." Each cubic inch additional volume connected to this port increases maximum time delay by 8 seconds.

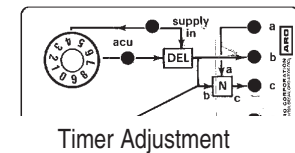

Sequence Controlled with Input Signals: If all steps are started by input signals, use one 59897 start/stop unit and an additional 59898 unit as required to complete the sequence.

Sequence Controlled by Time Delay Functions: If all steps are started by time delay (with the exception of the start button) use one piece 59895 start/stop unit and an additional 59896 to complete the sequence.

Both Input, Inhibit and Time Delay used to Control a Sequence: Mixed circuits are easily accomplished by selecting from the units previously mentioned, plus two more. Models 59899 and 59900 provide a combination of a time delay and an input signal functions in a single unit. Using the 59899 and 59900 gives you the exact unit needed for all mixed circuits.

Inhibitor: Inhibitor models (59920 through 59925) are used as the first, second or later circuit, depending on the application requirements. Inhibitors can be used to sense position of a cylinder, or other actuator, when limit switches are not appropriate.

Set-Up

Steps to Connecting Flex-6 Units

1. Arrange the units in the order and sequence they are used (steps 1 & 2 top, 3 & 4 next, etc.).
2. Connect a maintained supply to the "supply in" port of the first unit. Then connect the "supply out" of the first unit to the "supply in" of the second unit. Connect subsequent units in this manner. The last "supply out" port will remain plugged.

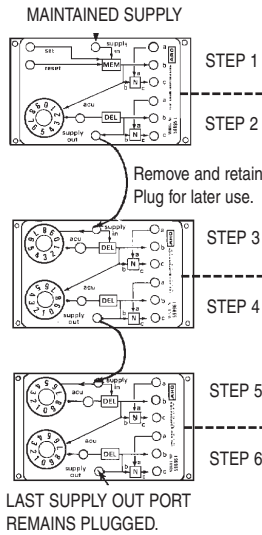

3. Connect the set input signals. The start signal and all other input signals are connected to the set ports of the units they will start.

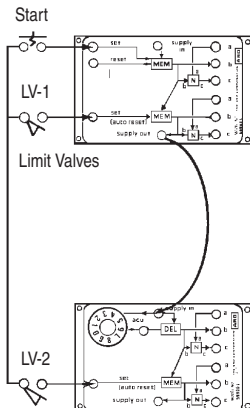

4. Connect and "program" the outputs. Each unit has three ports on the right side marked "A," "B," and "C." The "C" port is the output and is connected to the pilot valve or other device causing action for each stage. The "C" output signal can be removed by a signal (maintained) to the "A" port. The "B" ports are used to provide this maintained signal.

Example: Cylinder 1 extends in step 1 and retracts in step 4. The "C" port of step 1 is connected to a spring return pilot valve which extends the cylinder. The "B" port of step 4 is connected to the "A" port of step 1. This accomplishes the retract function.

NOTE: Once these connections have been made, plug all "B" and "C" ports not used. **"A" ports not used remain open.**

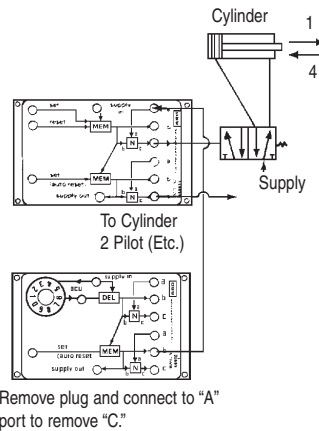

5. Connect the reset signal from the last step in sequence to the port marked "reset" in the first. This signal resets the circuit, making it ready to start a new cycle.

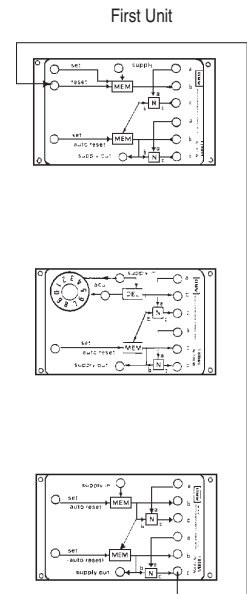

The Last Step of the Sequence is to RESET the Circuit

All Ports are 10/32 Threads

Features

Individual Units

59895 S/R Mem-Delay Model

The first unit in a Flex-6 circuit when step two is a delay function. The first output is caused by the start input signal. The second output is caused by a time delay following the first output. Flex 6 Dimensional Data is located on Pg.18.

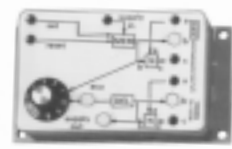

59895

59896 Double Delay

Used as the second unit, or later, in circuits when two time delay functions are needed. The first output is caused by a time delay after the supply signal is applied. The second output is caused by a time delay following the first output. Flex 6 Dimensional Data is located on Pg. 18.

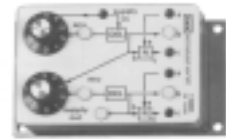

59896

59897 S/R Mem-Auto Mem Model

The first unit in Flex-6 circuits when step two is an input signal. The first output is caused by the start input signal. The second output is caused by a second input signal. Flex 6 Dimensional Data is located on Pg. 18.

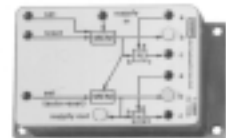

59897

59898 Double Auto Mem Model

Used as the second unit, or later, in circuits when two input signals are available. Both outputs are caused by their respective inputs and both are controlled by automatic reset memory functions. Flex 6 Dimensional Data is located on Pg. 18.

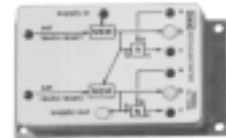

59898

59899 Auto Mem-Delay Model

Used as the second unit, or later, in Flex-6 circuits when an input signal and a delay function are required. The first output is caused by an input signal. The second output is caused by a time delay following the first output. Flex 6 Dimensional Data is located on Pg. 18.

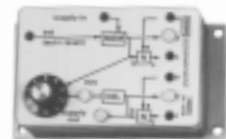

59899

59900 Delay-Auto Mem Model

Used as the second unit, or later, in circuits when a delay and an input signal are required. The first output is caused by delay function after the supply signal is applied. The second output is caused by an input signal. Flex 6 Dimensional Data is located on Pg. 18.



59900

Features

Individual Units

59919-1 Cycle Repeat Circuit

Cycle Repeat Circuit provides continuous recycling of a control circuit started by a momentary start signal, end of cycle stop — momentary input, single cycle operation, emergency stop and an adjustable dwell between cycles.

Add to any Flex-6 circuit so it cycles continuously.

Flex 6 Dimensional Data is located on Pg. 18.

See page 33 for additional information.



59919-1

59920 S/R Mem-Inhibitor Model

The first Flex-6 circuit when step two is an inhibitor function. The first output is caused by the start input signal. The second output is caused by the release of pressure on the inhibitor port.

Flex 6 Dimensional Data is located on Pg. 18.

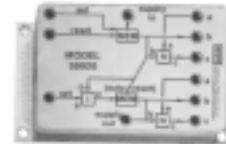

59920

59921 Inhibitor-Input Model

Used as the second or later circuit when the first stage will be controlled by an inhibitor signal and the second from a pressure signal.

Flex 6 Dimensional Data is located on Pg.18.

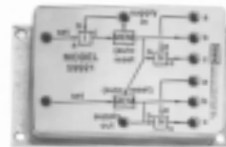

59921

59922 Delay-Inhibitor Model

Used as the second or later circuit when the first stage will be controlled by a delay and the second from an inhibitor signal.

Flex 6 Dimensional Data is located on Pg. 18.

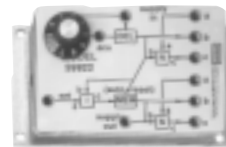

59922

59923 Double Inhibitor Mem Model

Used as the second or later circuit when both stages are started by inhibitor signals.

Flex 6 Dimensional Data is located on Pg. 18.



59923

59924 Input-Inhibitor Model

Used as the second or later circuit when the first stage will be controlled by a pressure signal and the second from an inhibitor signal.

Flex 6 Dimensional Data is located on Pg. 18.

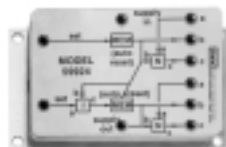

59924

59925 Inhibitor-Delay Model

Used as the second or later circuit when the first stage will be controlled by an inhibitor signal and the second from a delay.

Flex 6 Dimensional Data is located on Pg. 18.

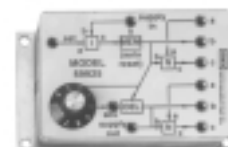

59925

Illustration 1

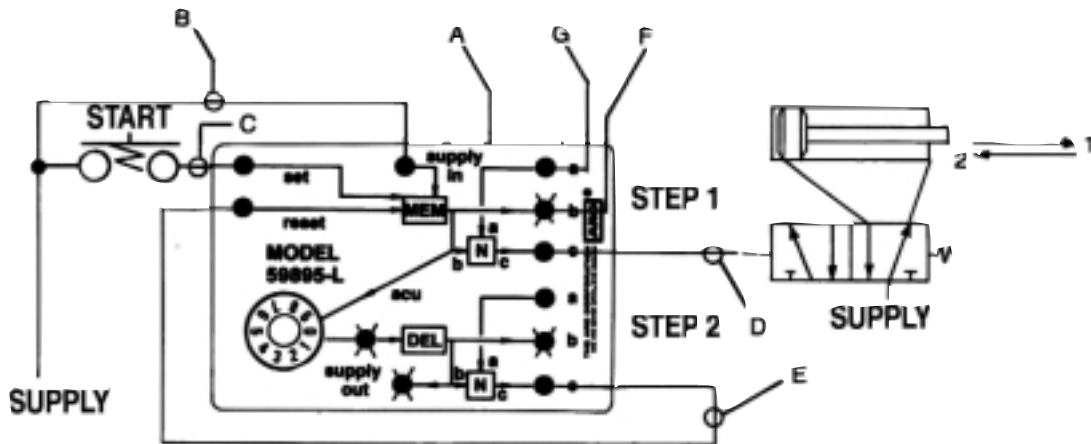

Description

Here we have a two step sequence using one cylinder. When a push button is actuated, the cylinder will extend for an adjustable period of time. When the time has elapsed, the cylinder will retract to its original position.

Connections

- A. This sequence uses a model 59895 Flex-6 unit.
- B. Supply is connected to the "Supply In" port.
- C. The output of a start push button is connected to the "Set" input port.
- D. The step 1 output (top "c" port) is connected to the pilot port of the valve which will extend the cylinder.
- E. The step 2 output (lower "c" port) is connected to the "Reset" input port.
- F. Both "b" ports, the "Supply Out" port, and the "ACU" port are plugged (new units are shipped with these plugs installed.)
- G. "a" ports, not used, remain open.

Function

1. At rest, the cylinder is retracted.
2. The operator presses the start push button. This signals the set port and step 1 output goes on immediately. The cylinder extends and the time delay is started. At this point the signal is "Locked In" and the operator can release the start push button. The time delay is adjustable. Turning the dial clockwise, extends the time setting.
3. When the adjusted time is expired, step 2 output goes on. Step 2 output signals the reset port. This causes the Flex-6 unit to reset* (unlocks the start signal) and outputs 1 and 2 go off., causing the cylinder to retract.
4. The circuit is now reset and ready for a new cycle when the start push button is again actuated.

*Set signal must be off for this to take place.

Illustration 2

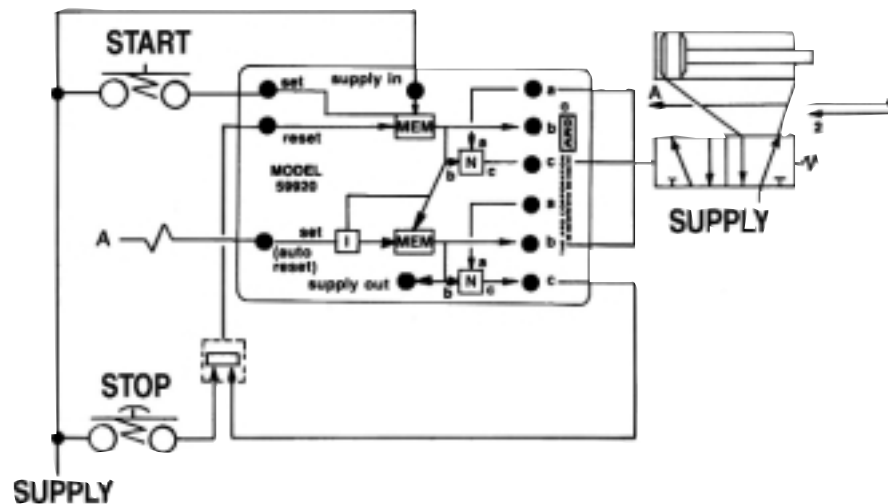

Description

Here we have a two step sequence described in Illustration 1. The difference is that the extension of the cylinder is sensed by the inhibitor element built into the 59920 Flex-6 unit. Again, when the cylinder is fully extended, the cylinder will retract.

Connections

- This sequence uses a model 59920 Flex-6 unit.
- The “A” connection is made from between the valve and the cylinder to the second set input.
- All other connections are identical to those made in Illustration 1, except that we have added a connection from “b” of step 2 to “a” of step 1. This will make the cylinder retract even if the operator continues to hold the button.

Options

The additional connection from the “b” port of the second stage at the “a” port of the first stage insures that the cylinder will return even if the operator continues to hold the start button.

An emergency stop push button has also been added. If the operator presses the emergency stop button, the circuit will reset and both cylinders will retract.

Function

- At rest, the cylinder is retracted.
- The operator presses the start push button. This signals the set port and step 1 output goes on. The operator can now release the start button.
- The cylinder now extends, and when fully extended or stopped mechanically, the signal at the second set port is fully released. This causes the step two output to go on retracting the cylinder and resetting the circuit.

Illustration 3

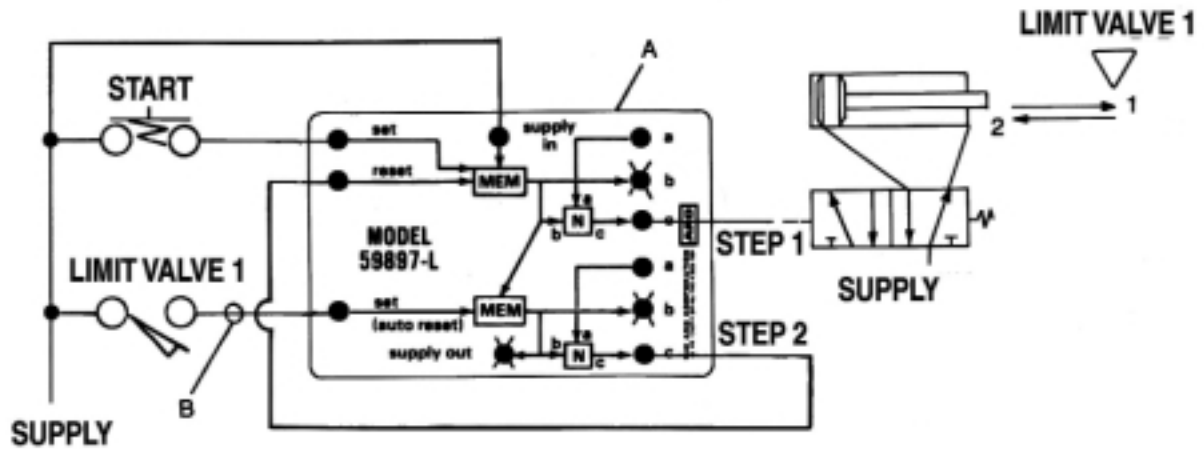

Description

Here we have a two step sequence described in Illustration 1. The difference is that this cylinder actuates a limit valve when it is fully extended. The limit valve signals the Flex-6 unit that the cylinder is extended and it is time to retract.

Connections

- A. This sequence uses a model 59897 Flex-6 unit.
- B. The limit valve output is connected to the port marked Set (Auto Reset)
- C. All other connections are identical to those made in Illustration 1.

Options

Option A, preventing the operator from holding the cylinder extended and Option B, providing an optional retract push button could be added to this circuit. These options are described in Illustration 2.

Function

1. At rest, the cylinder is retracted.
2. The operator presses the start push button. This signals the set port and step 1 output goes on immediately. At this point, the signal is "Locked In" and the operator can release the start push button.
3. The cylinder actuates the extend limit valve (LV-1). Limit valve 1 signals the step 2 set port. This causes the step 2 output to go on immediately. The step 2 output signals the reset port, which resets the circuit* removing the step 1 and 2 outputs and allows the cylinder to retract.

* Set signal must be off for this to take place.

Illustration 4

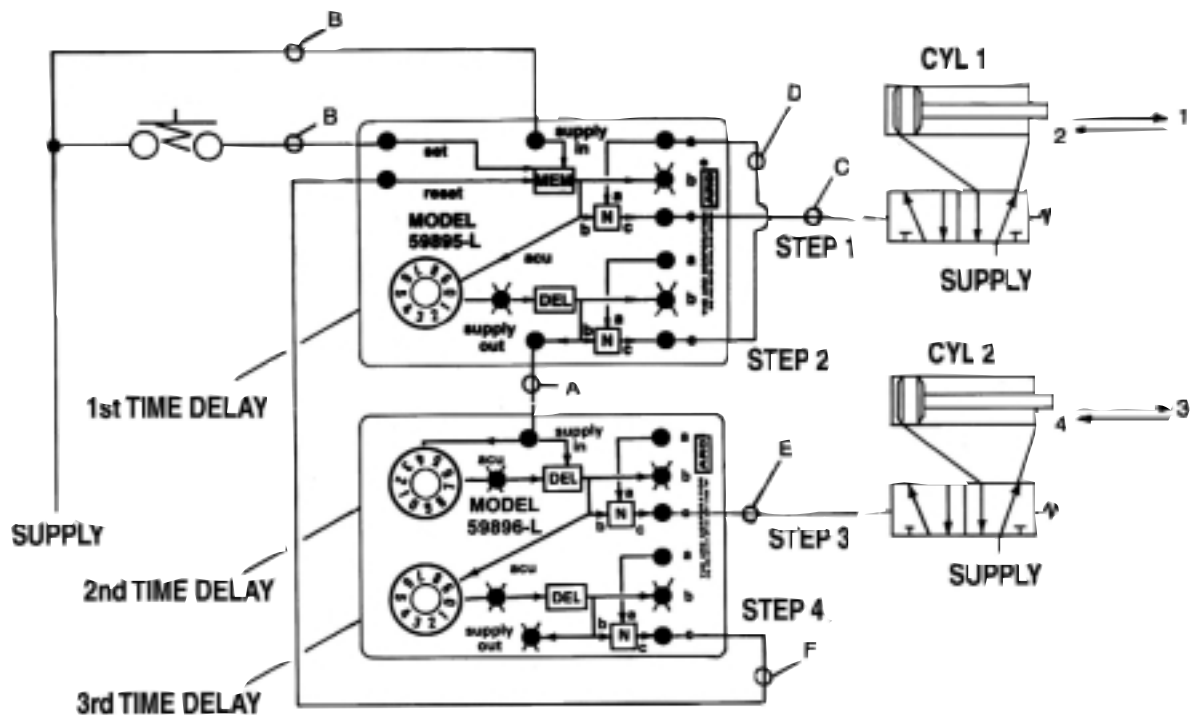

Description

Here we have a two cylinder four step sequence.

1. When the push button is actuated, cylinder 1 extends. This also starts the first time delay.
2. When the first time delay times out, cylinder 1 retracts. This starts the second time delay.
3. When the second time delay times out, cylinder 2 extends. This starts the third time delay.
4. When the third time delay times out, cylinder 2 retracts. This also resets the circuit.

Connections

This circuit uses a model 59896 Flex-6 unit.

- A. The 59896 is added to the circuit simply by removing the "Supply Out" plug in the 59895 and connecting this port to the "Supply On" port of the 59896.
- B. The supply and start push buttons are connected as before.
- C. The step 1 output is connected to the valve that extends cylinder 1.
- D. The step 2 output is connected to the "a" port of step 1.
- E. The step 3 output is connected to the valve that extends cylinder 2.
- F. The step 4 output is connected to the reset port.
- G. All "b" ports, all accumulator ports and the supply out of the 59896 are plugged.
- H. All "a" ports not used are left open.

Function

Looking closely at the diagram on top of the Flex-6 units, you may be able to trace the signals as the sequence progresses.

1. When the operator presses the start push button the signal sets the memory (MEM) in the first unit (MEM output on). This goes thru a "not" (N) element and to the step 1 output (CYL 1 extends). The output from the memory element is also connected to the first time delay by a diagonal line.
2. The output of delay 1 again goes through a "not" element to provide the step 2 output. This output is connected externally to the "a" input of step 1 and internally to the "a" port of the "not" element. This removes the output signal at step 1 and retracts cylinder 1. The output of delay 1 is also connected to the second time delay via the "supply out" to "supply in" connection.
3. Time delay 2 extends cylinder 2 and starts time delay 3.
4. Time delay 3 outputs resets the entire circuit and in doing so retracts cylinder 2.

Illustration 5

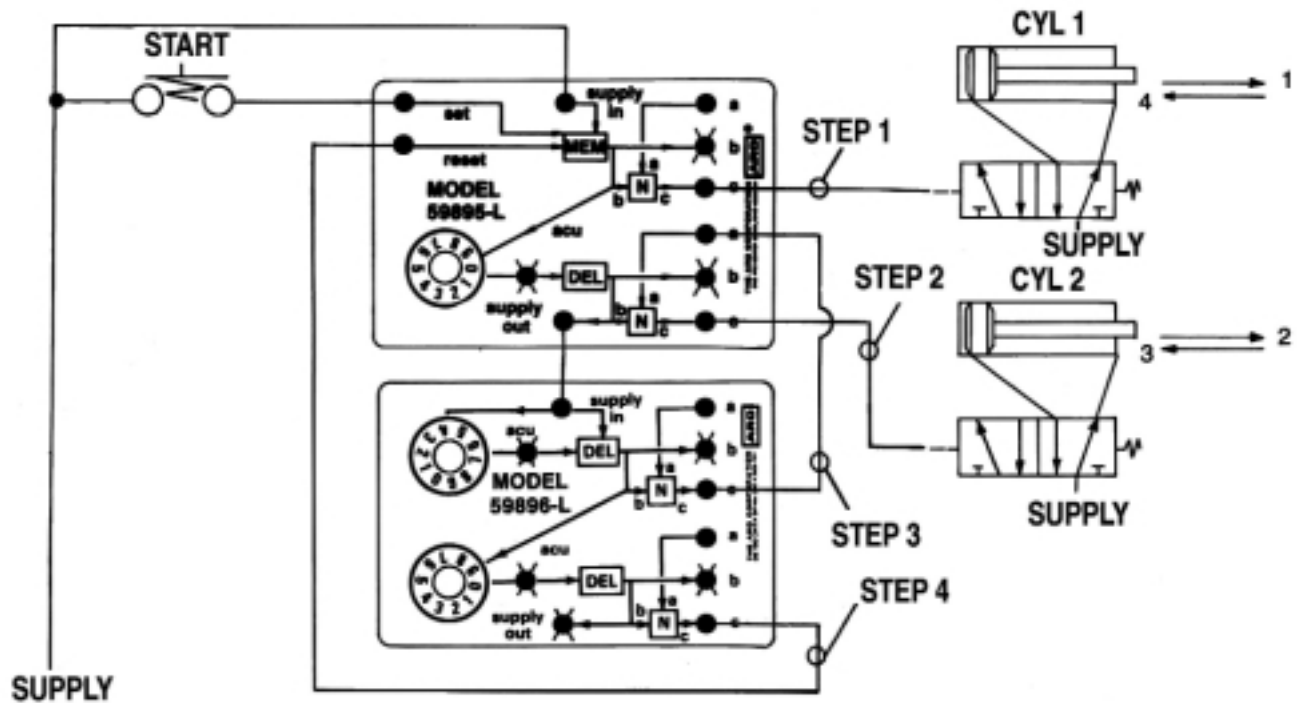

Description

Here we have a circuit similar to the one shown in Illustration 4. The difference between these circuits is the sequence that the cylinders extend and retract. This is shown by the numbered arrows to the right of the cylinders.

Connections

Notice that the change in sequence is done entirely by changing the output connections on the right hand side of the Flex-6 units.

- A. Step 1 output is connected to the valve that extends cylinder 1 (as before).
- B. Step 2 output is connected to the valve that extends cylinder 2.
- C. Step 3 output is connected to the "a" input port of step 2. This removes the step 2 output and retracts cylinder 2.
- D. Step 4 output is connected to the reset port (as before).

Thus by rearranging the output connections any sequence can be performed.

Options

1. To prevent the operator from holding cylinder 1 extended (by holding down the start push button), a connection can be made from the "b" port of step 4 to the "a" port of step 1.
2. An emergency retract push button can be added (See Illustration 2).
3. Additional accumulator and/or gauges can be added to each time delay (See Illustration 2).
4. Sequence step indicators can be added to the "b" ports (Model 59907-004).

Illustration 7

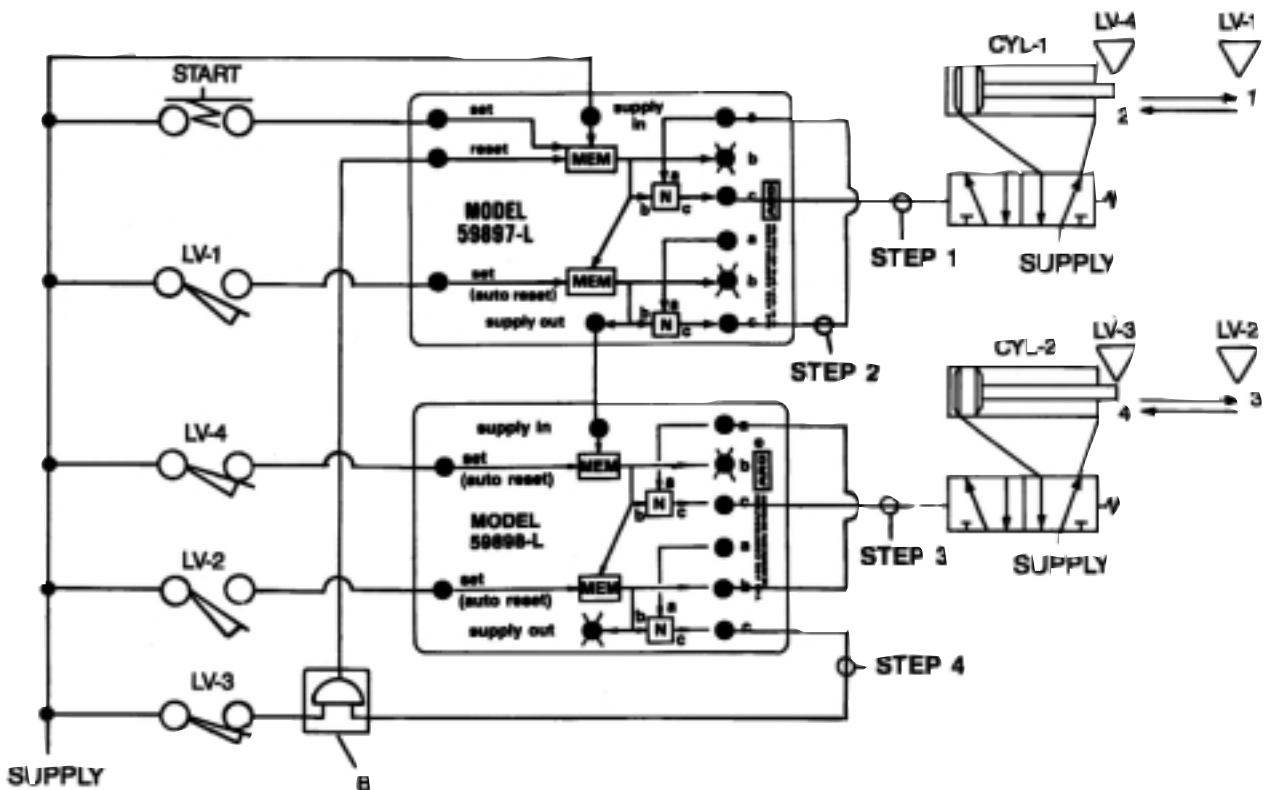

Description

This is the same sequence as shown in Illustration 4 except that limit valves are used to signal the start of each step. Two options (A & B) have also been added to the circuit.

- A. Option A cancels step 3 output and retracts cylinder 2 when output 4 comes on.
- B. Option B resets the circuit only after cylinder 2 is fully retracted.

Notes

The output connections and the input connections were changed from Illustration 6 to accomplish this sequence. Limit valve 4 was added so that each position of each cylinder could be detected. Step 5 is accomplished by “anding” step 4 output and the final limit valve input (LV-3). Using a 59913 in line “and” function. This could also be done by a series connection through limit valve 3.

This option is often used when each step of the sequence must be monitored closely. Example: continuous operating circuits.

Function

1. Operator actuates start push button. Cylinder 1 extends.
2. Cylinder 1 releases limit valve 4 and actuates limit valve 1. Step 2 output goes on retracting cylinder 1.
3. Cylinder 1 releases limit valve 1 and actuates limit valve 4. Step 3 output goes on extending cylinder 2.
4. Cylinder 2 releases limit valve 3 and actuates limit valve 2. Step 4 output goes on retracting cylinder 2.
5. Cylinder 2 releases limit valve 2 and actuates limit valve 3. Circuit resets and is now ready for a new cycle.

Illustration 8

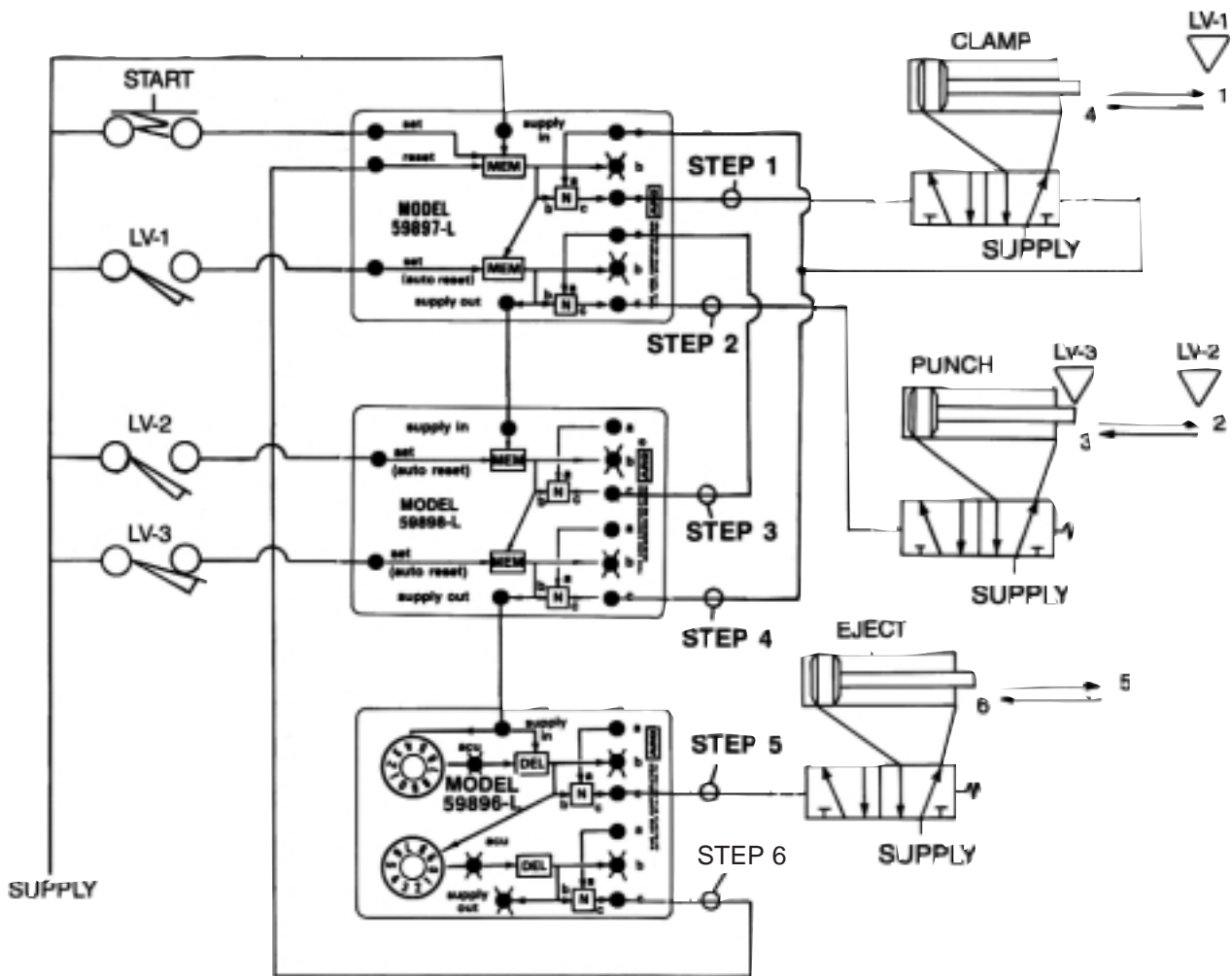

Description

Here is a six step sequence involving three cylinders. The sequence is as follows:

1. Operator actuates start push button. Clamp cylinder extends.
2. Clamp cylinder actuates limit valve 1. Punch cylinder extends.
3. Punch cylinder releases limit valve 3 and actuates limit valve 2. Punch valve retracts.
4. Punch cylinder releases limit valve 2 and actuates limit valve 3. Clamp cylinder retracts. Time delay 1 starts.
5. Time delay 1 times out. Eject cylinder extends, time delay 2 starts.
6. Time delay 2 times out. Eject cylinder is retracted and circuit is reset.

Variations

1. Both the 59898 (double input) and the 59896 (double timer) units are used in the same circuit.
2. This circuit also includes a double pilot valve on the clamp cylinder. Notice that the return pilot signal is simply tee'd from the signal that removes the step 1 output.

Illustration 9

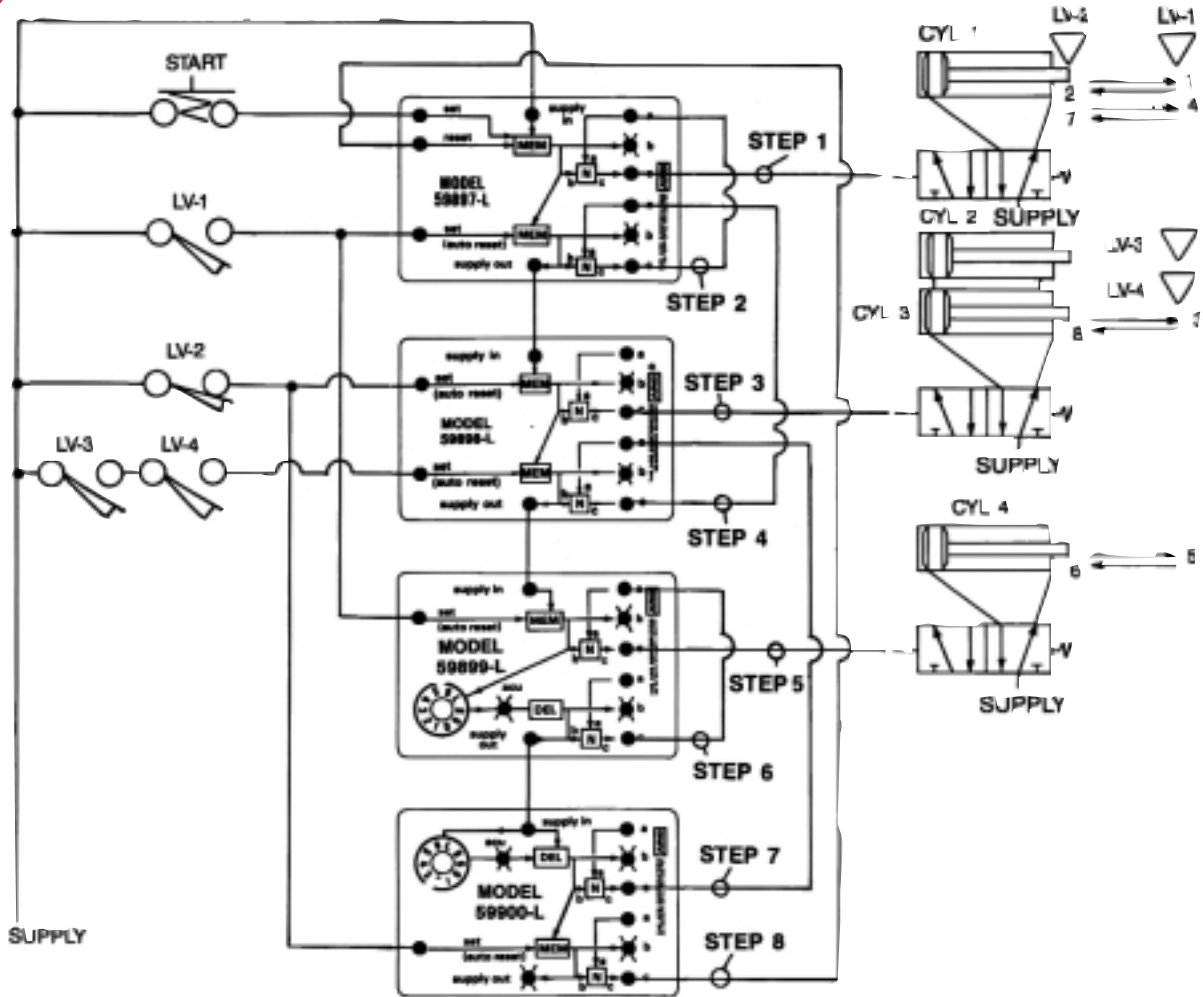

Description

The circuit in Illustration 9 shows several additional features of Flex-6 circuits.

1. Flex-6 circuits can include as many steps as necessary to complete the sequence. Additional Flex-6 blocks are simply added by connecting the “supply out” port of previous steps to the “supply in” port of new steps. Here we have 4 Flex-6 units providing 8 separate steps in the machine sequence.
2. We are also showing two new Flex-6 assemblies not previously shown. They are models 59899 and 59900 and are used in circuits such as this where some of the steps are controlled by timers and others by input signals.
3. Notice cylinders 2 and 3. When two cylinders work together their actions can be controlled by one step in the sequence. The only added provision here was to make sure both cylinder had fully extended before step 4 could take place. For this we provided limit valve 3 and 4. They can be connected in series (as shown) or “anded” together using a 59913 in line “and” function.
4. This drawing also shows a cylinder (cylinder 1) being extended and retracted twice in the sequence. First note how this is accomplished on the output side. Step one comes on and is later cancelled by step 2. Still later in the sequence step 4 output comes on, cancels step 2 and this allows step 1 to come back on. Finally step 7 comes on, cancels step 4, releasing step 2 and cancelling step 1. Notice also that limit valve 1 and 2 outputs can be used more than once in the same circuit. Simply tee their outputs and connect to the stage start ports indicated.

Other Six Element Assemblies

Four other six element assemblies are available. These units are sometimes used with Flex-6 circuits and in other cases provide a complete function in themselves.

Two-Hand Ant-Tie-Down Model 59191

The two-hand anti-tie-down is used to insure that both push buttons have been actuated before the cycle will start. When the anti-tie-down is used, both buttons must be actuated concurrently to create an output signal. Once either push button is released, the output signal goes off. Both push buttons must then be released and reactivated to start again.

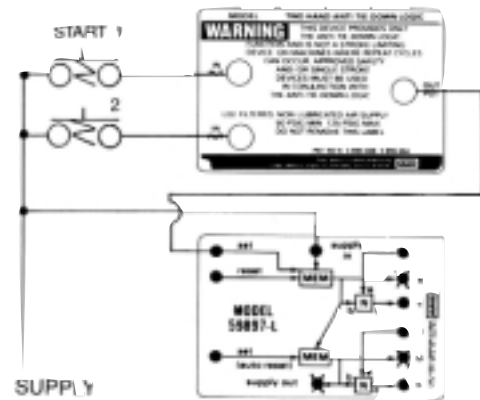

The first drawing shows a two-hand anti-tie-down added to the start of a Flex-6 circuit.

The second drawing shows a more complex circuit which is used to insure that the operator hold both buttons until cylinder 1 is fully extended. Once cylinder 1 is extended and actuates limit valve 1, the push buttons can be released and the machine will continue its automatic cycle.

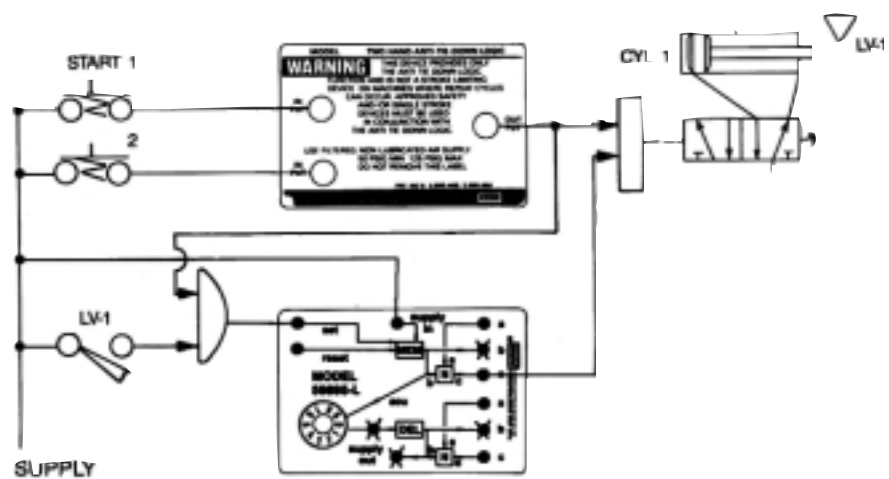

The Signal Standardizer Model 59860

The 59860 signal standardizer (or signal shaper) can be used to convert a signal of any duration to outputs of a predetermined time period.

When the start signal is received, the cylinder will extend for the period of time adjusted on the timer. Then the cylinder will retract. The start input signal can be shorter or longer than the output signal(s)* without affecting the timing function.

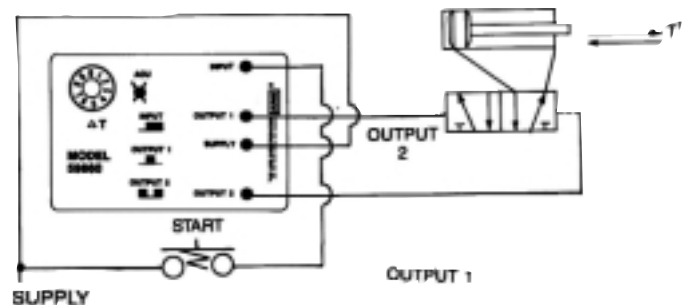

The Oscillator Circuit Model 59861

When a signal is received at the input of the oscillator circuit output T¹ will come on. After an adjustable period of time (adjustable at timer T¹) output T¹ will go off and output T² will go on.* After another adjustable period of time (adjustable at T²) output will go off and output T¹ will go on. This will continue as long as the input remains on.

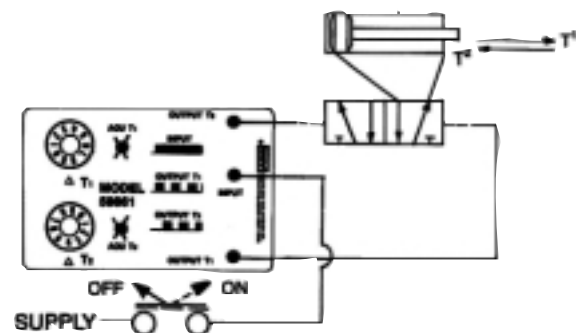

* Outputs not used can be plugged. Small cylinders can be ported directly to these outputs.

Cycle Repeat Circuit

Cycle Repeat Circuit Model 59919-1

This circuit is designed to replace the 59003-099 cycle repeat circuit.

The cycle repeat circuit shown can be added to any Flex-6 circuit so that it will recycle continuously. The circuit contained in this assembly is shown at the right.

1. The cycle repeat circuit provides for:
 - A. Continuous recycling of a control circuit, started by a momentary start signal.
 - B. end of cycle stop – momentary input.
 - C. An adjustable dwell between cycles.
 - D. Single cycle operation.
 - E. Emergency stop.

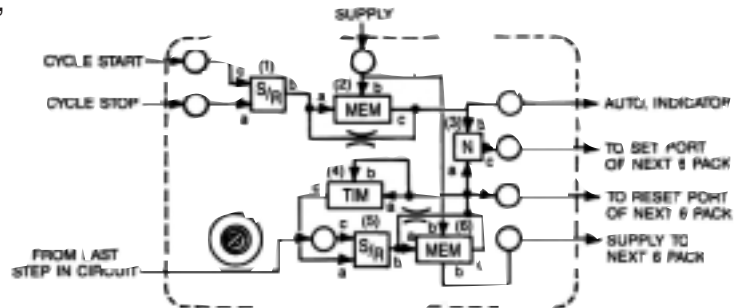
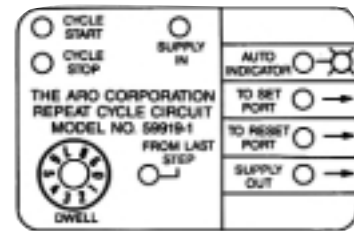

The illustration at right shows a cycle repeat circuit connected in its simplest form. Actuation of the start push button starts the circuit to run in an auto-recycle mode. When the cycle stop push button is actuated the circuit will complete that cycle and will not start the next cycle. If you want the cycle to stop immediately, add the connection shown by the dotted line.

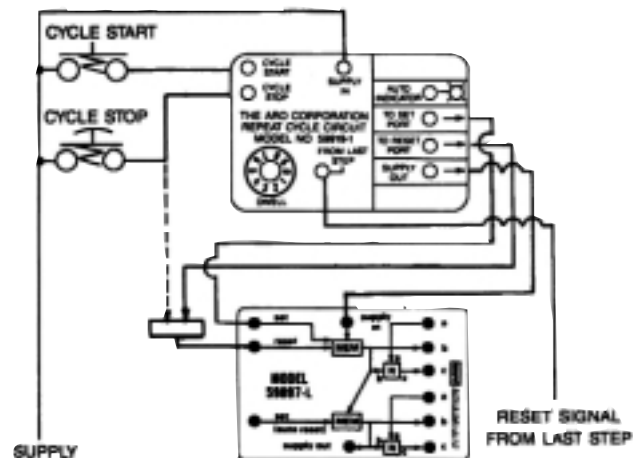

The illustration at right shows a more complex application of the cycle repeat circuit. Here we have provisions for either single cycle or automatic cycling and an auto cycle indicator. The circuit can be stopped either at the end of the cycle (with the auto cycle stop push button) or immediately (with the emergency stop button).

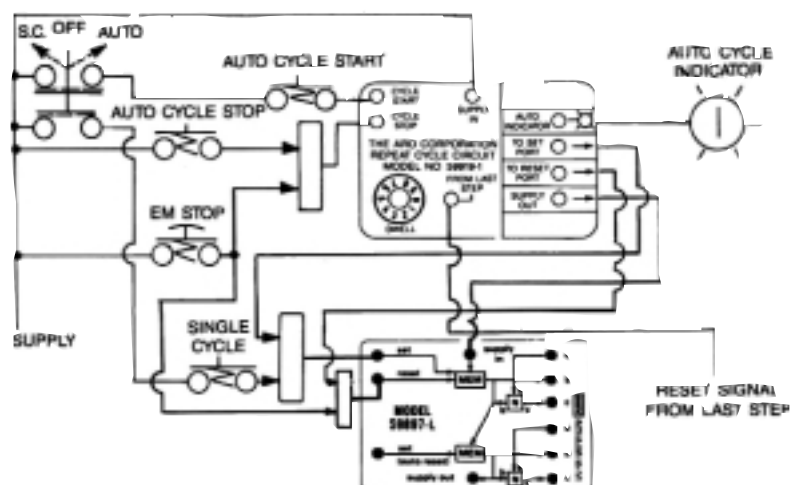

Features

Individual Elements

59010 "OR" Element

59023 "OR" Element on 1/8" Base

- Combines two air signals so either can produce an output.
- Output port C is pressurized when either input port A or B is pressurized "on".

Dimensions: 1 1/4" sq. x 1" (31.8mm sq. x 25.4mm)

Response Times: Input to Output Milliseconds

"A" on to "C" on	7.5
"B" on to "C" on	7

Truth table

A	B	C
1	0	1
0	1	1
1	1	1
0	0	0



59010

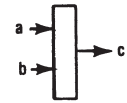

59111 "AND" Element

59124 "AND" Element on 1/8" Base

- Combines two signals so both must be on to create an output.
- Output port C is pressurized only when both inputs A & B are pressurized "on".
- Can be used with timer elements to produce time-delay functions.
- Shifting is snap-action when input at "A" port increases to 70% of pressure at "B" port. Return when "A" decreases to 40% of "B".

Dimensions: 1 1/4" Sq. x 1 21/32" (31.8mm sq. x 42.1mm)

Response Times: Input to Output Milliseconds

"A" on to "C" on	8
"A" off to "C" off	9.5

Truth table

A	B	C
1	0	0
0	1	0
1	1	1
0	0	0



59111

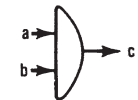

59112 "NOT" Element

59125 "NOT" Element on 1/8" Base

- Combines two signals so that one ("B") must be on, and the other ("A") must be off to create an output.
- Output C is pressurized only when input B is pressurized and input A is off.
- Shifting is snap-action when input at "A" increases to 70% of pressure at "B". Return when "A" decreases to 40% of "B".

Dimensions: 1 1/4" Sq. x 1 21/32" (31.8mm sq. x 42.1mm)

Response Times: Input to Output Milliseconds

"A" on to "C" off	8.5
"A" off to "C" on	9

Truth table

A	B	C
1	0	0
0	1	1
1	1	0
0	0	0



59112

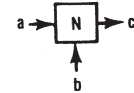

59800 Inhibitor Element

59192 Inhibitor Assembly on 1/8" Base

- Functions as NOT element except pressure at A must drop below 5% of supply before element will reset, regaining output at C.
- Useful in detecting air cylinder motions where limit valves cannot be applied.

Response Times: Input to Output Milliseconds

A on to C off	15
A off to C on	25

Truth table

A	B	C
1	0	0
0	1	1
1	1	0
0	0	0



59800

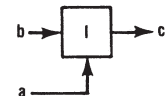

59181 Set-Reset (S-R) Gate and 59113 Memory Models

59185 Set-Reset (S-R) Gate and Memory Assembly on 1/8" Base

- The elements work together to perform a memory function.
- With constant supply at B of MEM and B of S-R connected to A of MEM, a momentary pressure signal at C of S-R will cause C of MEM to pressurize. C of MEM will remain pressurized until a pressure signal to A of S-R is received.
- The MEMORY is pneumatically retained. If supply is removed (B MEM off), output C will go off & remain off until a new set signal is received.
- The reset signal ("A" of S-R) is snap-action function and can be connected to a TIMER element to create a delayed reset function.

Dimensions: 1 1/4" sq. x 1 21/32" (31.8mm x 42.1mm)

Minimum Time: Signal Milliseconds

To SET	17
To RESET	19



59181



59113

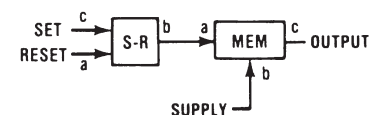

Features

Flip-Flop

59892 "FLIP FLOP" Model

- A memory type element, Flip-Flop converts momentary signals received at the set and reset ports into maintained corresponding outputs.
 - A set signal at A shifts the Flip-Flop to C port on and resets D to off. A reset signal at F shifts the Flip-Flop to D on and C off.
 - If set or reset signals are maintained, later signals of equal pressure to the opposite input will not alter the output condition.
 - The Flip-Flop has six ports and requires two element spaces.

A Set Input	D Reset Output
B Supply	E Supply
C Set Output	F Reset Input
 - 59892 has two top ports (10-32) for C & D outputs.
 - Shift pressure is 50% of supply pressure.
- Dimensions: 2 1/2" x 1 7/32" (63.5mm x 36.5mm)



59892

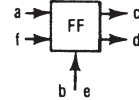

Approximate Response Time	
Input to Output	Milliseconds
A on to C on	11
F on to D on	11

Delay Elements & Assemblies

DELAY ELEMENTS

- Combine an AND and a TIMER function.
- With supply present at B, output will be pressurized (C on) a predetermined amount of time after input A is pressurized. Time can be fixed or adjustable.
- Reset time (time signal at "A" must be off between cycles) is 100 milliseconds.
- Timing ranges for individual elements cannot be increased. For longer delays, a base mounted assembly is needed.



59121

DELAY TIMING IN FUNCTIONS

1. With the input off, the output will also be off.
2. The timing function starts when the input goes on.
3. When the timing is complete, the output goes on.
4. Output goes off immediately when input is removed.



59158

Screwdriver Adjustable Delay Units

- ±4% timing accuracy.

Individual Element

59121 Timing Range: .08 to 7.5 seconds

Base Mounted Elements (1/8" Base)

59158 Timing Range: .08 to 7.5 seconds

59879 Timing Range: 4.1 to 27.5 seconds



59156

Dial Adjustable Delay Units

- ±4% timing accuracy.

Individual Element

59156 Timing Range .08 to 7.5 seconds

Base Mounted Elements (1/8" Base)

59160 Timing Range: .08 to 7.5 seconds

59880 Timing Range: 4.1 to 27.5 seconds



59166-4

59166-4 Fixed Delays

- Not adjustable. Order model for desired time.
- Dimensions: 1 1/4" sq x 2 3/4" (31.8mm sq. x 69.9mm)

Model	Milliseconds
59166-4	445 ± 40



Dimensions for Base Assemblies are on page 40.

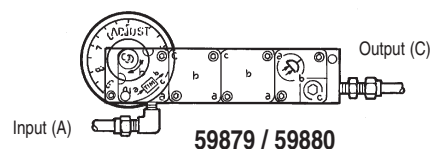

59879 / 59880

Features

Pulse Elements & Assemblies

PULSE ELEMENTS

- Combine a NOT and a TIMER function.
- These perform TIMING-IN inverted or PULSE functions, depending on connections to supply port B.

For TIMING-IN INVERTED function: With port B pressurized, C port remains on until port A is pressurized. When A is pressurized, C will go OFF after a predetermined amount of time.

PULSE function: When A & B are connected together, output C is normally off. If inputs are applied to A & B, output C goes on. C remains on for timer period, then goes off and remains off until inputs are removed and reapplied. Reset time is 100 milliseconds. The predetermined amount of time can be fixed or adjustable.

1. With input off, the output will also be off.
2. Output goes on & timing starts when input comes on.
3. When timing is completed, output goes off.
4. Remove & reapply input to get second output.

NOTE: Input must be longer than output for full times signal. If not possible, see momentary timers.

Screw Adjustable Pulse Timers

- ±4% timing accuracy.

Individual Element

59120 Timing Range: .08 to 7.5 seconds

Base Mounted Elements (1/8" Base)

59157 Timing Range: .08 to 7.5 seconds

59874 Timing Range: 3.0 to 17.5 seconds

59881 Timing Range: .20 to 27.5 seconds

Dial Adjustable Pulse Timers

Individual Element

59155 Timing Range: .08 to 7.5 seconds

Base Mounted Elements (1/8" Base)

59159 Timing Range: .08 to 7.5 seconds

59875 Timing Range: 3.0 to 17.5 seconds

59882 Timing range of 4.6 to 27.5 seconds

59165-4 Fixed Pulse

- Not adjustable, order model for time desired; ±10% timing accuracy.

Dimensions: 1 1/4" sq x 2 3/4" (31.8mm sq. x 69.9mm)

Model	Milliseconds
59165-4	445 ± 40

59114 Differentiator

- A non-adjustable pulse element.
- With A blocked, signal at B will produce an output at C of 80 to 130 milliseconds. Output can be lengthened by connecting a 59117 Accumulator to port A.
- Reset time is 110 milliseconds.

Dimensions: 1 1/4" sq. x 1 3/4" (31.8mm sq. x 44.5mm)

Dimensions for Base Assemblies are on page 40.



59120



59157

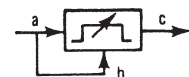

59155



59165-4

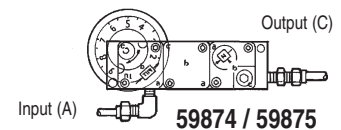

59874 / 59875

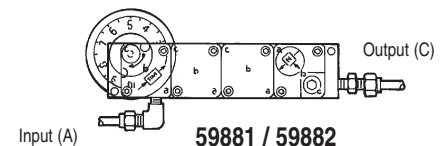

59881 / 59882



59114



Features

Timer Elements

TIMERS are used in conjunction with snap-acting 59111 AND, 59112 NOT, 59181 S-R GATE or 59800 INHIBITOR to perform special functions not offered in one complete element.

- Overall height of circuit board can be reduced by using these combinations rather than elements which combine these functions.
- Timing periods can exceed 7.5 seconds when using with 59117 Accumulators.
- Time can be fixed or adjustable, depending on element selected.



59115 Screw Adjustable Timer

- Connected to A of snap-acting AND or NOT element, these timing ranges can be accomplished.

Dimensions: 1 1/4" sq. x 2 7/64" (31.8mm sq. x 53.6mm)

Timer	Number of 59117 Accumulators	Timing Range ±4% Seconds
59115	0	.08 to 7.5
59115	1	.14 to 17.5
59115	2	.20 to 27.5
59115	3	.26 to 37.5
59115	4	.32 to 47.5



59115

59116 Dial Adjustable Timer

- Connected to A of snap-acting element, these timing ranges can be accomplished.

Dimensions: 1 1/4" sq. x 3 5/16" (31.8mm sq. x 84.1mm)

Timer	Number of 59117 Accumulators	Timing Range ±4% Seconds
59116	0	1.4 to 7.5
59116	1	3.0 to 17.5
59116	2	4.6 to 27.5
59116	3	6.2 to 37.5
59116	4	7.8 to 47.5



59116

Accumulator

59117 Accumulator

- Used with timing elements to extend timing range. C port is connected to output of timing element. Volume is approximately 1 cu. in. (16.4 cm³).

Dimensions: 1 1/4" sq. x 2 1/16" (31.8mm sq. x 52.4mm)



59117



Fixed Orifice plates and Port Plug

- Can be mounted in inlet or outlet ports of any element to reduce flow and/or increase response time.
- Fits into O-Ring cavity of element base.
- Plug is used to isolate port from channel connection.

Model	Orifice Size Inches (mm)
59671-1	.0135 (.343)
59671-2	.0180 (.475)
59671-3	.0225 (.572)
59671-4	.0260 (.660)
59718	Plug



59671-X

Features

NOT Amplifier

59176 NOT Amplifier

- The element converts low pressure signals such as those used in liquid level sensing, to high pressure signals compatible with other APLC elements.
- Performs NOT function with exception when C output is greater than input of A₁.
- Input A & B ports must be interconnected externally of element.
- Output C is on only when low pressure at A₁ is off. C output equals pressure at A & B.
- Shift pressure depends on element ordered and adjusted setting.
- Sensitivity adjustment screw allows adjustment of shift point within adjustable range.

Dimensions: 1 1/4" sq. x 3" (31.8mm sq. x 76.2mm)

Individual Element	Approximate Response Time Input to Output Milliseconds	Adjustable A1 Pressure Range PSIG when a & b = 50 PSIG (3.4bar)
59176-1	A ₁ on to C off 10	.24 to 1.5 (0.11 to .07)
59176-2	A ₁ off to C on 10	1.5 to 15 (0.7 to 1.0)

Element on Base Assys.	Approximate Response Time Input to Output Milliseconds	Adjustable A1 Pressure Range PSIG when a & b = 50 PSIG (3.4bar)
59162-2	A ₁ off to C on 10	1.5 to 15 (0.7 to 1.0)

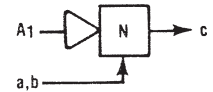

59176-X

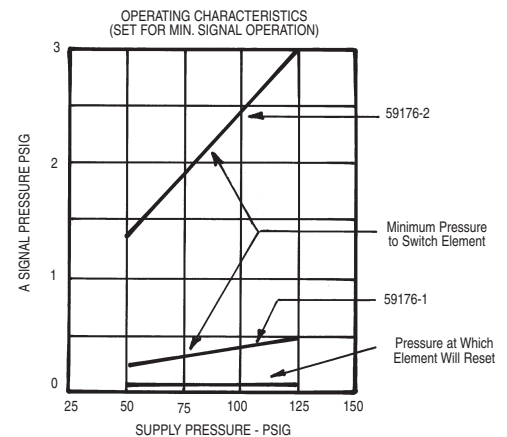

AND Amplifier

59175 "AND" Amplifier

- The amplifier converts low pressure signals such as those used in liquid level sensing, to high pressure signals compatible with other APLC elements.
- Performs AND function except when output at C is greater than input A₁.
- Inputs A & B must be interconnected externally of the element.
- Output C is on only when A₁ receives a low pressure signal and inputs A & B are pressurized. Output at C equals pressure at inputs A & B.
- Shift pressure depends on element ordered and adjusted setting.
- Sensitivity adjustment screw allows adjustment of shift point within adjustable range.

Dimensions: 1/4" sq. x 3" (31.8mm sq. x 76.2mm)

Individual Element	Approximate Response Time Input to Output Milliseconds	Adjustable A1 Pressure Range PSIG when a & b = 50 PSIG (3.4bar)
59175-1	A ₁ on to C on 10	.24 to 1.5 (0.11 to .07)
59175-2	A ₁ off to C off 10	1.5 to 15 (0.7 to 1.0)

Element on Base Assys.	Approximate Response Time Input to Output Milliseconds	Adjustable A1 Pressure Range PSIG when a & b = 50 PSIG (3.4bar)
59161-1	A ₁ on to C on 10	.24 to 1.5 (0.11 to .07)
59161-2	A ₁ off to C off 10	1.5 to 15 (0.7 to 1.0)

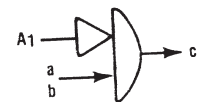

59175-X

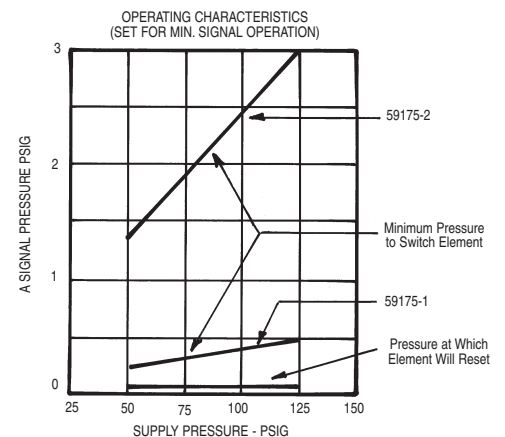

Dimensions for Base Assemblies are on page 40.

Features

Special Purpose Elements

59089 Two to Three-Way Converter

- Used to convert a two-way (bleed signal) to a three-way (pressure-exhaust) signal.
- With supply B pressurized, C will be pressurized if A is not blocked. When A port is blocked, C will go off.

Dimensions: 1 1/4" sq. x 1 21/23" (31.8mm sq. x 42.1mm)

Approximate Response Time

<u>Input to Output</u>	<u>With 6" (152mm) 5/32" (4mm) Tubing to A--Milliseconds</u>	<u>Add Milliseconds for each Foot more Tubing</u>
A open to C on	14	5.5
A blocked to C off	70	32.5
Start up B to C pulse	90	33.5



59089

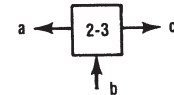

59890 Vibrator Element

59866 Vibrator on 1/8" Base

- With input B on, C output will come on and go off in a constant timed pattern until the input is removed.
- The on and off times are not independently adjustable.
- Adjustment timing range: .08 to 7.5 seconds. Output off equals 80% of on setting.
- C port must also be connected to the A input port on element.



59890

20191 Circuit Board Mounted Poppet Valve

- 3-Way poppet with 1/4" ports. Plumb normally open (passing) or closed (non-passing.)
- Pilot signal port comes from any one of A, B, C ports on Circuit Cover Plate.
- Flow is 46.4 SCFM (21.9 dm³/s) at 90 PSI (6.3 bar) supply and 75 PSI (5.2) outlet. Cv Factor - 1.3.
- Mounts directly to circuit board, utilizing space of one standard element. Must be mounted at periphery of circuit.

Dimensions: 1 15/64" x 1 1/2" x 2 31/32" (31.4mm x 38.1mm x 75.4mm)



20191

59891 Air to Electric Interface Device

- Normally open, single throw, single pole pressure switch.
- Mount to top of C port of standard element.

Dimensions: 1 7/16" dia. x 2 1/4" Wire is 22AWG

<u>Model</u>	<u>Supply</u>	<u>Output</u>	<u>Connections</u>	<u>Response Time</u>
59891	30-150 PSI	5 Amps Max	1/8-27 NPT	On - 1 ms Off - 4 ms



59891

59915-XX Electric to Air Interface Device

- Normally non-passing, three-way, single solenoid actuated valve.
- With B pressurized and the coil energized, an air output occurs at C port.
- When de-energized, B is blocked and C exhausted.
- Must be mounted on perimeter of circuit board.

<u>Model</u>	<u>Supply</u>	<u>Output</u>	<u>Connections</u>	<u>Coil Replacement</u>
59915-38	12V DC/24 VAC	Air Signal	A blocked	116218-38
59915-39	24V DC	30-150PSI	B supply	116218-39
59915-33	120V AC	(2-10 bar)	C output	116218-33



59915-XX

Porting Block

59109 Porting Block

- Provides three instant tube fittings. One each to A, B or C ports of elements.
- One porting block required for each element.

Dimensions for Base Assemblies are on page 40.



59109

Features

Mounting Equipment

59200-XX Base Plate

- Contains two mounting holes and three porting holes for each element.
- Surface is metallic grit etched and plated to resist corrosion.

59595-88 Module Gasket

- Corresponding circuit pattern of layout sheet is printed on module. Air channels are then cut into gasket for air passage.

59201-XX Cover Plate

- Used in conjunction with 59200 base plate to retain 59595 module.
- Contains only the mounting holes required by elements.
- Surface is metallic grit etched and plated to resist corrosion.

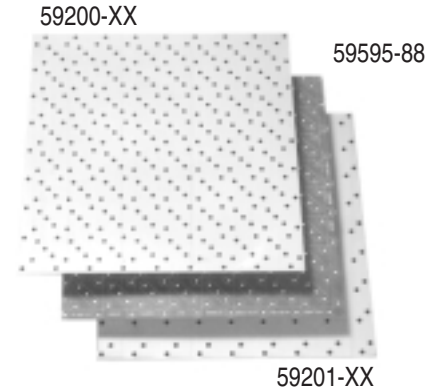

Model:	Dimensions in Inches (Millimeters)	Element Coverage
Base Plate		
59200-24	5/64 x 3 21/64 x 5 53/64 (2 x 85 x 148)	2 x 4
59200-44	5/64 x 5 53/64 x 5 53/64 (2 x 148 x 148)	4 x 4
59200-66	5/64 x 8 21/64 x 8 21/64 (2 x 212 x 212)	6 x 6
59200-88	5/64 x 10 45/64 x 10 45/64 (2 x 272 x 272)	8 x 8
Module Gasket		
59595-88	1/16 x 10 45/64 x 10 45/64 (2 x 272 x 272)	8 x 8
Cover Plate		
59201-24	5/32 x 3 21/64 x 5 53/64 (4 x 85 x 148)	2 x 4
59201-44	5/32 x 5 53/64 x 5 53/64 (4 x 148 x 148)	4 x 4
59201-66	5/32 x 8 21/64 x 8 21/64 (4 x 212 x 212)	6 x 6
59201-88	5/32 x 10 45/64 x 10 45/64 (4 x 272 x 272)	8 x 8

Base Assembly Method

- Simple logic functions requiring up to four elements can be mounted using the function base assembly method.
- Interconnections between elements are made in a module below the elements. External connections are made via the 1/8" NPTF ports on the porting blocks.



59062
Base Assembly

Model:	Base Assembly	# of Ports	Components
59387	1-Element	3	Base, Washer & nuts.
59061	2-Elements	6	Base, Cover plate, module, pipe plugs, nuts and washers.
59062	3-Elements	8	
59063	4-Elements	10	

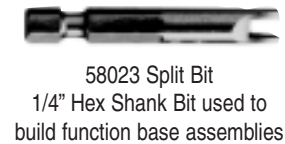

58023 Split Bit
1/4" Hex Shank Bit used to build function base assemblies

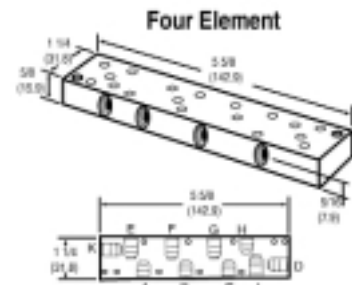
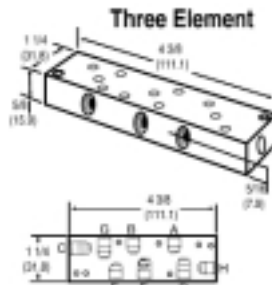
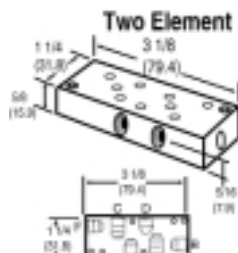
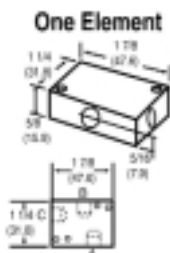

Features

Multiple Snap Indicator

- Bright sleeve within indicator extends to indicate pressurized condition. Sleeve retracts when pressure is removed.
- Snap-in design for installation into 11/16" (17.5mm) hole.

Pressure Range: 30-150 PSI (2.1-10.4 bar)

59812-1 Red Indicator 1/8" Ports

59812-3 Green Indicator 1/8" Ports

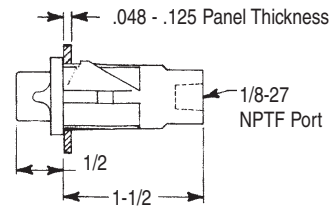

59812-X Dimensional Data

Snap Flag Indicators

- Pressurized condition indicated by colored flag in window.
- Superior distance indication.

Pressure Range: 30-150 PSI (2.1-10.4 bar)

59073 Red Indicator 1/8" Ports

59107 Green Indicator 1/8" Ports



59812-X

59073

Element Test Indicators

- Used to indicate an output pressure signal from an element.
- Thread into test port of "OR", "AND" or "MEM" elements.

59084 Red pin extends under pressure. Spring Return.

59422 Test Valve to thread on gauge.

24130 Press to test indicator.



Panel Mounted Miniature Control Valves & Indicators

- Uses basic 200 Series 3-way valves.
- Valves are available with push button or rocker type selectors.
- Both valves and indicators come complete.
Order mounting plates and legend sheets separately.

59796-X Mounting Plates (with dimensions)

Model	# of Controls	"A"	"B"	Height
59796-1	1	1-11/16"	9/16"	3-7/8"
59796-2	2	2-3/8"	1-1/4"	3-7/8"
59796-4	4	3-3/4"	2-5/8"	3-7/8"
59796-6	6	5-1/8"	4"	3-7/8"

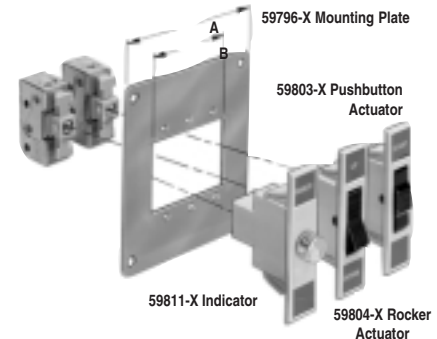

Panel Mounted Indicators

Model	Color	Port
59811-1	Red	1/8" NPTF
59811-3	Green	1/8" NPTF

3-Way Control Valve Assembly

1/8" Ports	Tube Fittings	Actuation Type	Port Designation
59803	59803-1	Pushbutton (Momentary)	1-in, Non-Passing
59804	59804-1	Rocker (Maintained)	3-in, Passing 2-Output

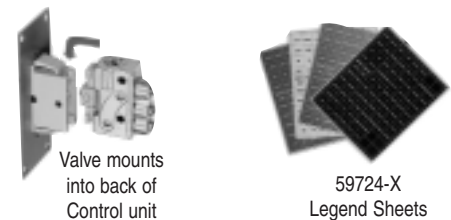

59724-X Legend Sheets

Self-adhesive. They fit into recesses of valves and indicators.

Model	Color
59724-1	Black
59724-2	White
59724-3	Green
59724-4	Red

Dimensions and Mounting Information

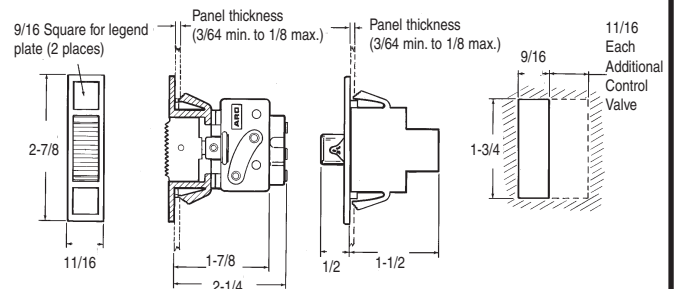

Features

Control Enclosures

58027

- Accepts single push button, selector or palm button valves.
 - Standard 1/2" and 3/4" conduit knock-outs at top and bottom.
- Dimensions: 4 3/8" x 4 3/8" x 3 5/8" (111.1mm x 111.1mm x 82.1mm)

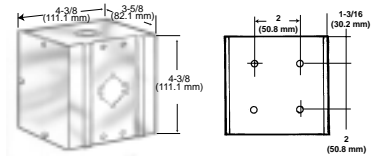

58027

59361

- Accepts four push button, selector or palm button valves.
 - Standard 1/2" and 3/4" conduit knock-outs at top and bottom.
 - Includes grommets, screws, washers and nuts for installation.
- Dimensions: 4 3/8" x 10" x 3 5/8" (111.1mm x 254mm x 82.1mm)

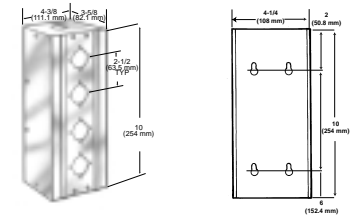

59361

59792

- Accepts single push button, selector or palm button valves.
 - Standard 1/2" and 3/4" conduit knock-outs at top and bottom.
 - Additional space provided for circuitry.
- Dimensions: 4 3/8" x 10" x 3 5/8" (111.1mm x 254mm x 82.1mm)



59792

Enclosures

58060 Two Compartment Enclosure

- Accepts 6 x 6 element circuit board.
 - Rear compartment provides access to terminal connections and back of circuit board.
 - Pre-drilled pads for terminals and mounting rails.
- Dimensions: 11 9/16" x 11 23/32" x 8 7/32" (294mm x 298mm x 209mm)



58060

59097-6 Hinged Mounting Plates

- Accepts 6 x 6 element circuit boards.
- Provides mounting and swing-out of circuit boards.
- Requires 5/8" (15.9mm) clearance for circuit boards, 2 3/8" (60mm) for back tubulation.



59097-6

<u>Circuit Bds</u>	<u>Elements</u>	<u>Dimensions</u>
59097-6	6 x 6	9 1/2" x 10" (241 x 254mm)

Features

Pneumatic Counters

Totalizing Counters/Manual Reset

59095-1 Knob Reset/Base Mount

- Counter advances one digit each time a pneumatic pulse is received.
- 600 counts/minute maximum.

59095-2 Dial Reset/Panel Mount

- Counter advances one digit each time a pneumatic pulse is received.
- 600 counts/minute maximum. Can also be base mounted.

59095-3 Key Reset/Panel Mount

- Counter advances one digit each time a pneumatic pulse is received.
- 600 counts/minute maximum. Can also be base mounted.

Specifications

Operating Pressure: 30 to 150 PSIG (2 to 10 bar)
Operating Temperature: 32° to 160°F (0° to 71°C)

Minimum Signal Duration: Pressure Signal 0.05 sec.
Ports: 1/8" NPTF

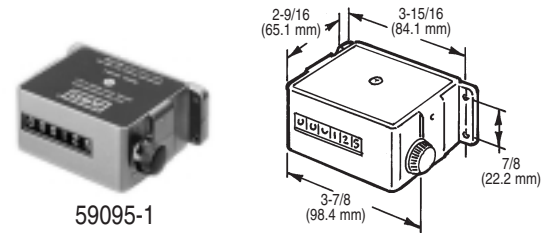

59095-1

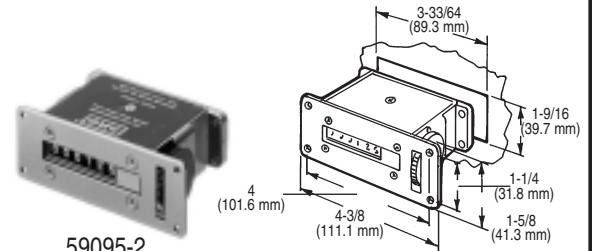

59095-2

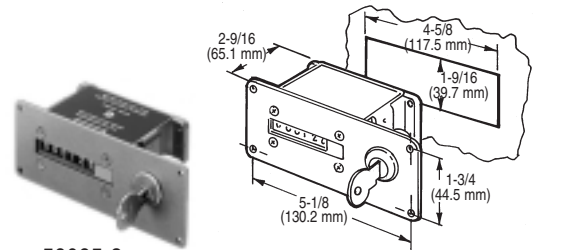

59095-3

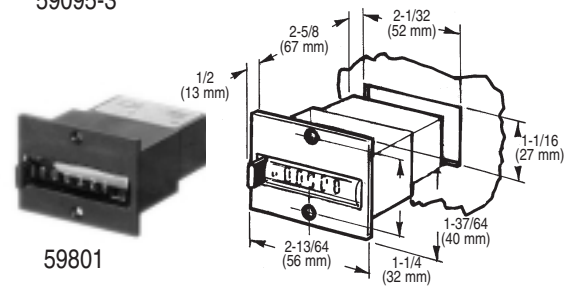

59801

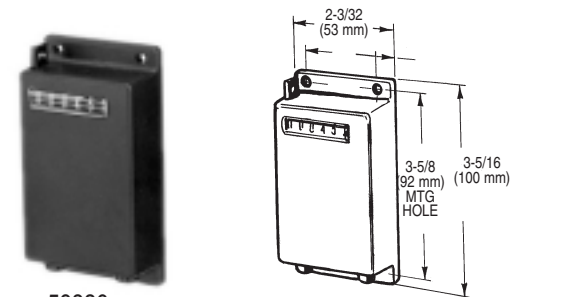

59836

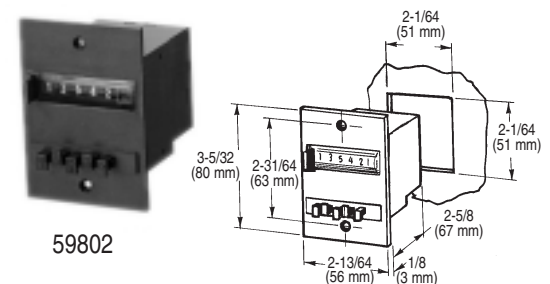

59802

Totalizing Counter/Manual or Pressure Reset

59801 Panel Mount

59836 Surface Mount

- 6-digit readout. Records up to 1500 counts/minute
- Can be reset using reset button or pneumatic signal.

Specifications

Operating Pressure: 30 to 115 PSIG (2 to 8 bar)
Operating Temperature: 32° to 140°F (0° to 60°C)

Minimum Signal Duration: Pressure Signal .008 sec.
Exhaust Signal .010 sec.
Reset Signal .150 sec.
Ports: 5/32" (4mm) Tube Fittings

Predetermined Counter/Manual or Pressure Reset

59802 Panel Mount

- 5-digit readout.
- Each pneumatic pulse decreases predetermined number by one until zero is reached. An output signal is then provided.
- Counter is reset to predetermined number by the reset button or a pneumatic signal.

Specifications

Operating Pressure: 30 to 115 PSIG (2 to 8 bar)
Operating Temperature: 32° to 140°F (0° to 60°C)

Minimum Signal Duration: Pressure Signal .008 sec.
Exhaust Signal .012 sec.
Reset Signal .180 sec.
Ports: 5/32" (4mm) Tube Fittings
Flow: 4.5 SCFM (2.1 dm³/s)

Port Designation:
P (3) Supply, A (4) Output,
Z (1) Count, Y (2) Reset.

Features

- Provides actuation of up to 12, 3-way valves in different positions.
- Each can be plumbed normally passing, normally non-passing, multipurpose, selector or any 2-way function.
- Cam lobes snap on in any of 12 positions.
- Available with 5/32" tube fittings or 1/8" ports.
- Pressure Range 30-150 PSI (2.1-10.4 bar)



59100-XXX-1

Model # for 1/8" Ports	Model # for 5/32" Tubes	Number of Camwheels	Number of Cam Lobes	Valves
59100-202	59100-202-1	2	2	22
59100-222	59100-222-1	2	4	24
59100-303	59100-303-1	3	3	33
59100-333	59100-333-1	3	6	36
59100-404	59100-404-1	4	4	34
59100-444	59100-444-1	4	8	38
59100-505	59100-505-1	5	5	45
59100-555	59100-555-1	5	10	50
59100-606	59100-606-1	6	6	56
59100-666	59100-666-1	6	12	62

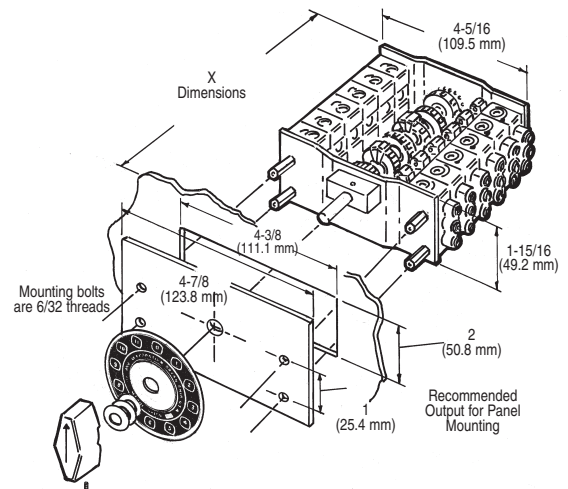

Model Number Significance:

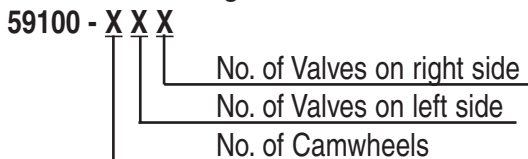

Model # "X" Dimensions Inches (mm)

59100-2XX	2-27/64 (62mm)
59100-3XX	3-7/64 (79 mm)
59100-4XX	3-51/64 (96 mm)
59100-5XX	4-31/64 (114 mm)
59100-6XX	5-11/64 (131 mm)

Liquid Level Sensor

- Sensors produce a pneumatic output signal as fluid levels in an unpressurized vessel rise or fall past predetermined levels. Will accurately sense almost any fluid.
- Supply pressure range: 30 to 150 psig. Range recommended for quickest response is 50 to 100 psig.
- When on, the output is the same pressure as that supplied to the air inlet. When off, the output is connected to atmosphere through an internal exhaust port. This insures a sharp on-off signal from the sensor.
- Units supplied with 25' of flexible 1/4" tubing.

59916-1 High Level Sensor

- Provides an output signal when sensing tube is blocked by a liquid.

59916-2 Low Level Sensor

- Provides an output signal when sensing tube is not blocked by a liquid.



59916-X

Features

Pneumatic Sensing Components

59807 Amplifier

- Designed to amplify low pressure signals from sensors.
- Actuates at signal pressures as low as one to four inches (249 to 995 Pa) of water.



59807

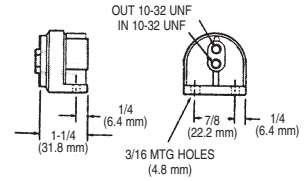
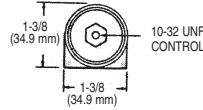

Tubing, Fittings & Connectors

<u>Y-Connector</u>	<u>Tube Size</u>	
59482	5/32	
<u>Male Connector</u>	<u>Tube Size</u>	<u>NPT</u>
59474-4	5/32	1/8
59474-56	1/4	1/8
59474-156	1/4	1/4
59474-256	1/4	3/8



<u>Union</u>	<u>Tube Size</u>
59759-4	5/32
59759-56	1/4



<u>Union Elbow</u>	<u>Tube Size</u>
59760-4	5/32
59760-56	1/4



<u>Tubing (100' rolls)</u>	<u>Tube Size</u>
59690-4	5/32



<u>Union Tee</u>	<u>Tube Size</u>
59761-4	5/32
59761-56	1/4



<u>Male Elbow</u>	<u>Tube Size</u>	<u>NPT</u>
59756-4	5/32	1/8
59756-56	1/4	1/8
59756-156	1/4	1/4



<u>Union Bulkhead</u>	<u>Tube Size</u>
59762-4	5/32
59762-56	1/4



<u>Male Branch Tee</u>	<u>Tube Size</u>	<u>NPT</u>
59757-4	5/32	1/8
59757-56	1/4	1/8
59757-156	1/4	1/4



<u>Expander Tube Male</u>	<u>Tube Size</u>	<u>NPT</u>
59765-4	5/32	1/4



<u>Plug</u>	<u>Tube Size</u>
59763-4	5/32
59763-56	1/4



<u>Reducer Tube Male</u>	<u>Tube Size</u>	<u>NPT</u>
59765-56	1/4	5/32

Maximum Working Pressure Vacuum to 250 PSI (17 bar)
Temperature Range - +5°F to 160°F (-15°F to 71°C)
Tubing Material: Nylon II

Flex-6 Accessories

59629 Adapter
1/8" to 10-32 Thread



59634 Cross Junction
10-32 Thread



5990X Push On Connector
59905: 10-32 NPT x 1/16" Tube
59906: 10-32 NPT x 1/8" Tube



5963X-100 Flexible Tubing
59630-100: 1/16" ID.
59631-100: 1/8" ID.



59764-4 Male Connector
10-32 Thread x 5/32" Tube



59908 Nipple
10-32 x 10-32 Thread



59632-1 Plug
10-32 Thread



59903 Swivel Connector



59636 Bulkhead Fitting
10-32 x 10-32 Thread

P.O. Box 151 • One Ar
Bryan, Ohio 43506-01



**Ontario's Largest
Pneumatic & Hydraulic Tool Distributor**

(419) 636-4242 • FAX (419) 633-1772

1-2430 Lucknow Drive, Mississauga, Ontario L5S 1V3. Tel: 905-672-5557 Fax: 905-672-5559

Fluid Handling: (Customer Service)
(419)633-1794 • FAX (419)633-1772

Email: sales@dobcoeqp.com www.dobcoeqp.com

Fluid Power: (Customer Service)
(419)633-1796 • FAX (419)633-1774

Web: www.arozone.com

LATIN AMERICA

Latin America Headquarters

Ingersoll-Rand PEG
Aro Division
730 N.W. 107 Ave., Suite 300
Miami, FL 33172-3107
PH: (305) 222-0812/559-0500
FAX: (305) 222-0864/559-7505

Brazil

Ingersoll-Rand do Brasil Ltda.
Av. Dr. Cardoso de Melo 1855
Cep. 04548-005 São Paulo S.P. 55
11 822 7400
PH: (55-11) 822-7400
FAX: (55-11) 866-4985

Chile

Ingersoll-Rand Chile, Ltda.
Nueva Tajamar 555
Oficina 1502
Santiago, Chile
PH: 56-2 339-7939
FAX: 56-2 339-7940

Mexico

Ingersoll-Rand, S.A. de C.V.
Blvd. Centro Industrial No.11
Industrial Puente de Vigas
54070 Tlanepantla, Edo. Mex.
PH: (525) 3 90 40 21 Ext. 109
FAX: (525) 3 90 40 31

EUROPE

European Headquarters

Europe, Africa & Middle East
Ingersoll-Rand
Zone du Chêne Sorcier
B.P. 62
Les Clayes sous Bois
Cedex - France
PH: (33) 01 30 07 69 50
FAX: (33) 01 30 07 69 96

PH: (81) 45-476-7807
FAX: (81) 45-476-7806

Singapore

Ingersoll-Rand S.E.A. Pte Ltd.
42, Benoi Road
Singapore 2262
PH: (65) 8611555
FAX: (65) 8610317

Australia

Ingersoll-Rand Australia, Ltd.
1 Hartnett Drive
Seaford, Vic 3198
PH: (61) 3 9554-1600
FAX: (61) 3 9554-1611

China / Hong Kong

Ingersoll-Rand Hong Kong
Suite 1201-3, 12 Floor,
Central Plaza
18 Harbour Road
Wanchai, Hong Kong
PH: (852) 2527-0183
FAX: (852) 2529-5976

Korea

Ingersoll-Rand Korea
Production Equipment Group
#1005, 10th Floor,
Guhsung Bldg.
541, Dohwa-Dong
Mapo-Ku, Seoul
Korea
PH: (82) 2-703-8461 / 3
FAX: (82) 2-3272-5894

Taiwan

Ingersoll-Rand Taiwan
12F-2, No. 79
Shin-Tai Wu Road
Sec. 1, Hsi-Chih Town
Taipei Hsien, Taiwan, R.O.C.
PH: 886-2-698-4858 Ext. 18
FAX: 886-2-698-9897

Get in the
IR ARO
ZONE

